

PolyVac

Pneumatic conveying system

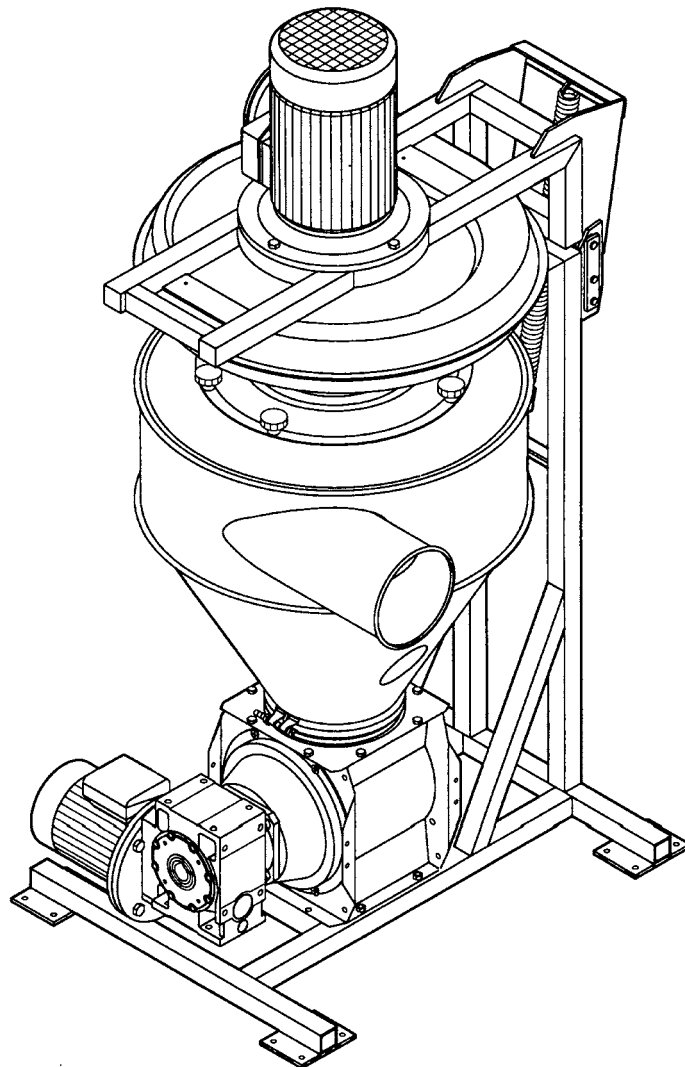

Manual

POLYVAC 30/50 - Standard units with Gaylord height stand and dust collection
Fig. 1

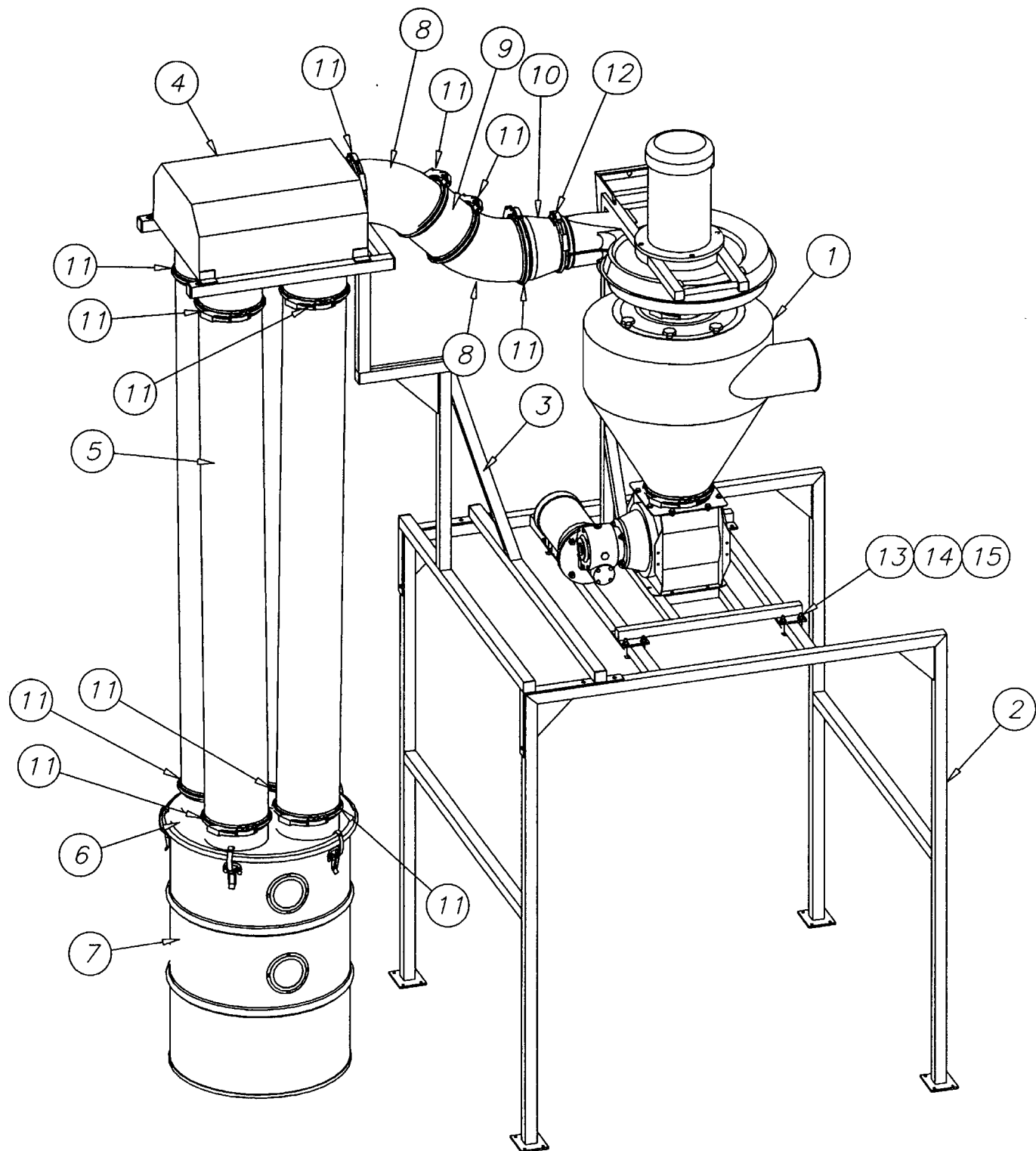

Assembly Instructions - Standard units with Gaylord height stand and dust collection

All instructions refer to Figure 1 on page 2

For proper assembly, follow steps listed below.

- a: Mount the Polyvac unit (1) on the stand (2) using U-bolts (13), flat washers (14) and lock nuts (15).



Make certain that the foundation is secure, and check regularly that all the mounting bolts are tight.

- b: Attach the filter manifold support arm (3) on the stand (2).
- c: Attach first the OK160/200 transition (10) to blower outlet with OK160 clamp (12). Then mount 45° bend (8), OK200 pipe (9), and again a 45° bend (8) using OK200 clamps. Attach the 4 bags manifold (4) on the support arm and clamp it to the bend (8).
- d: Place drum (7) with lid (6) under the 4-bag manifold and installs the four filter socks (5). The filter socks are slid over the OK adapters on drum lid and manifold and secured with OK200 clamps. Make sure there is approximately 1 inch of material slid through the clamp.

List of Equipment			
15	8	600366003	5/16" Lock-nut
14	8	100331014	M8 Flat Washer - Plated
13	4	600373028	5/16" x 2-1/2" x 60mm U-bolt
12	1	122000800	OK160 Quick Release Clamp, galv.
11	12	122050101	OK200 Quick Release Clamp, grey
10	1	121000367	OK160/OK200 Transition, grey
9	1	122000455	OKD200 x 0.15m Pipe, grey
8	2	122050115	45° OK200 Bend, galv.
7	1	699114492	45 Gallon Drum w. Window
6	1	699114237	4 x OK200 Inlet Drum Lid.
5	4	699114055	OK200 x 2m Filter Sock
4	1	699114441	4 Bag Manifold w. Side Inlet
3	1	699115792	Polyvac 4 Bag Manifold Bolt-on Stand
2	1	699115160	Polyvac Stand
1d	1	123110003	Polyvac 50, 5hp, 3ph, 575V-60Hz
1c	1	123110002	Polyvac 50, 5hp, 3ph, 460V-60Hz
1b	1	123110001	Polyvac 30, 3hp, 3ph, 575V-60Hz
1a	1	123110000	Polyvac 30, 3hp, 3ph, 460V-60Hz

POLYVAC 30/50 - Standard Units with Suction Flexhose
Fig. 2

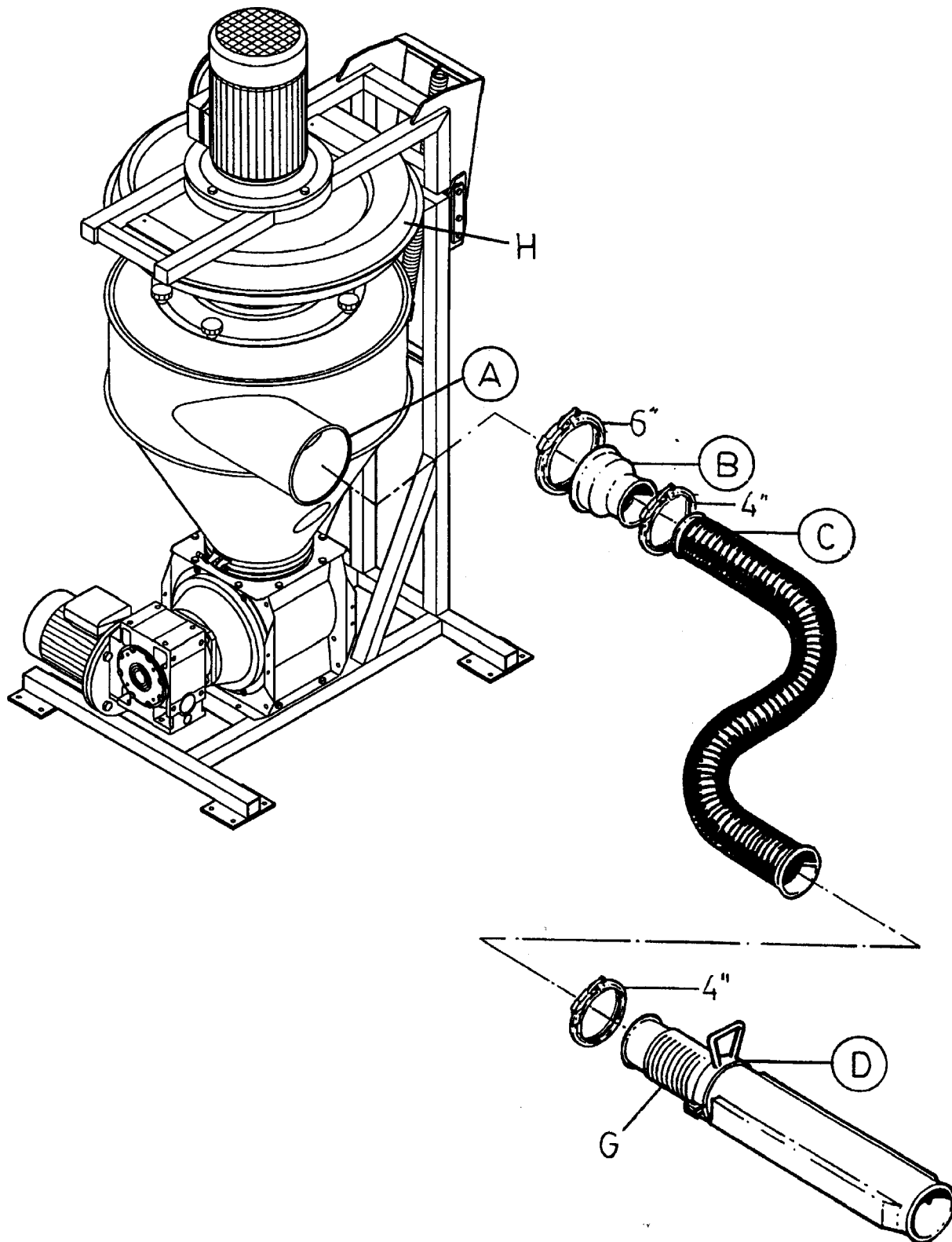

Assembly Instructions - Standard Units with Suction Flexhose

All instructions refer to Figure 2 on page 4

- a: Rotate the Cyclone Inlet (Item A) for the best working position of the Suction Flex hose. Loosen, but do not remove, the clamps on both top and bottom of the cyclone. Rotate the cyclone to the desired position, retighten the clamps.
- b: Install the 4" Suction Flex hose. (Item C) First the OK160 (6") to OK100 (4") adapter (Item B) must be clamped to the cyclone. The Flex hose is then connected with the OK100 (4") quick clamp.
- c: Install the Suction Wand (Item D) to the Flex hose. Make sure the air intake and handle are located at the end nearest the hose.

POLYVAC 30/50 - SUC Unit
Fig. 3

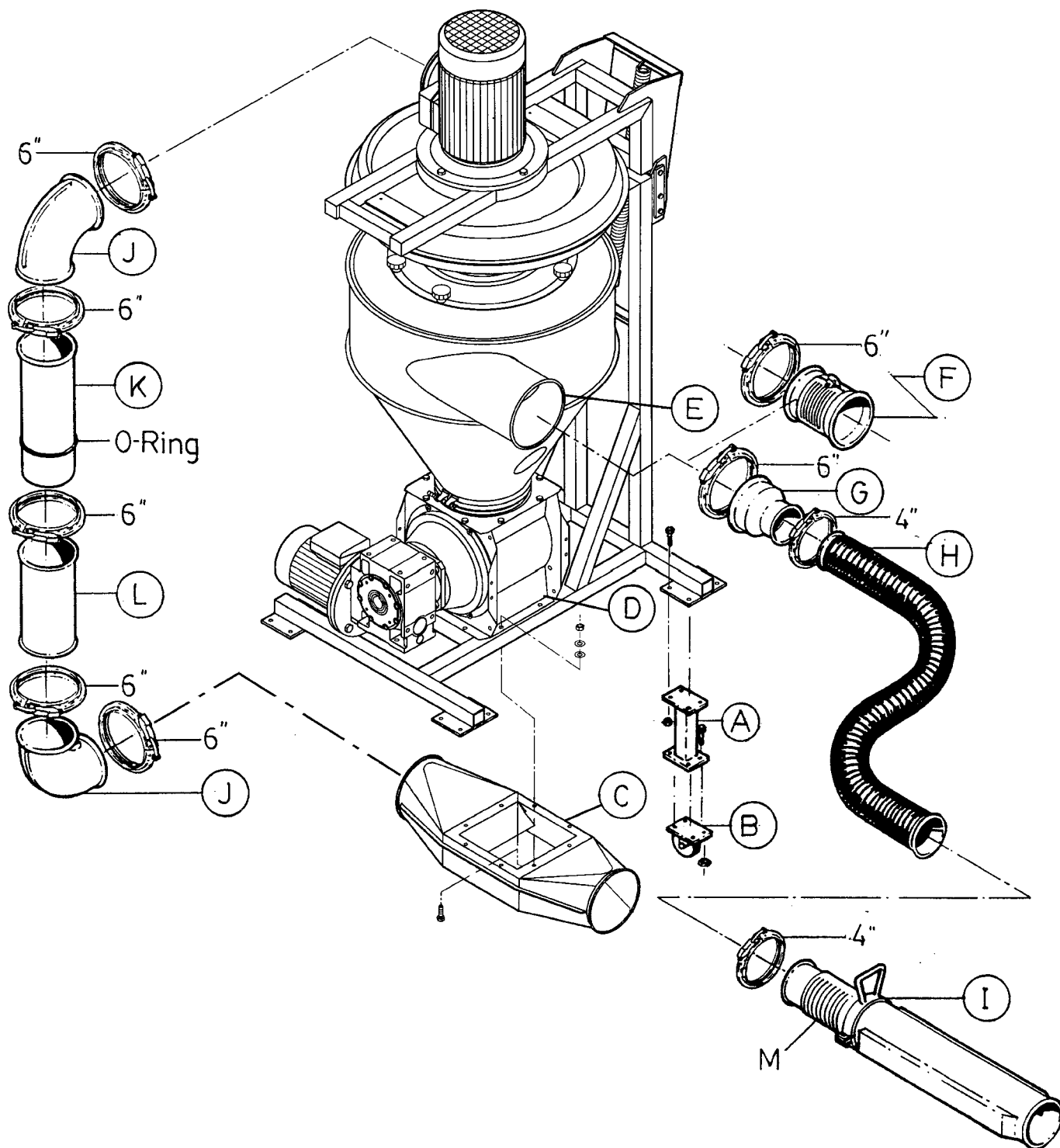

Assembly Instructions - SUC Unit

For proper assembly, follow steps below. See Figure 3, Page 6.

- a: Attach the 4 leg extensions (Item A) to the bottom of the POLYVAC stand. Requires 16, 1/4 x 3/4" bolts.
- b: If the POLYVAC unit is to be mobile, attach the 4 optional caster wheels (Item B). Requires 4, 1/4 x 3/4" bolts.
- c: Mount the Blow Through Unit (Item C) on the bottom of the Rotary Valve (Item D). Requires 4, 5/16 x 2" bolts.
- d: Mount the POLYVAC unit in a suitable location using the bolt plate on the legs of the stand.



Make certain that the foundation is secure, and check regularly that all mounting bolts are tight.

- e: Rotate the Cyclone Inlet (Item E) for the best working position of the Suction Flex hose. Loosen, but do not remove, the clamps on both top and bottom of the cyclone. Rotate the cyclone to the desired position, and retighten the clamps.
- f: Attach the Variable Air Intake (Item F) to the Cyclone with OK160 (6") clamp.
- g: Install the 4" Suction Flex hose. (Item H) Clamp the OK160 (6") to OK100 (4") adapter (Item G) to the variable air intake. Then connect the Flex hose with the OK100 (4") clamp.
- h: Install the Suction Wand (Item I) to the Flex hose. The air intake and handle are located at the end nearest the hose.
- i: Install the Intermediate Piping (Item J to L) between the Fan outlet and the Blow Through Unit.
 - 1: Attach the 90° Degree (Item J) elbows to the Fan outlet and to the Blow Through using the clamps.
 - 2: Slide the telescopic pipe with rubber O'Ring (Item K) inside the 12" pipe (Item L).

Note: The seams of the pipe must be aligned for proper function of the telescopic pipe.

- 3: Mount the telescopic pipe between the elbows adjusting the pipe to the desired length. Secure both ends with the pipe clamps.
- 4: Slide the rubber O'Ring down the pipe until it rests on the other pipe lip. Place the pipe clamp around O'Ring and the pipe lip, and secure clamp.
- j: Install electrical power to the motor. Follow electrical wiring instructions on the inside of motor electrical box.

Note: Make sure the motor is turning in the proper direction as shown by the arrow on the fan housing.

All electrical work must comply with local regulations.

Operation of POLYVAC - Standard Unit

- a: When using the POLYVAC to draw material from gaylords, bin, etc., a certain amount of air is required in the pipe to keep the material fluidized. This secondary air is allowed in by adjusting the air intake (Item G) on the Suction Wand (Item D, Page 4).

By **closing** the intake, the conveying capacity is **increased**.

Note: Do not close off intake too far as material will stop flowing and lay in the hose. Material must continue to flow.

By **opening** the intake, the conveying capacity is **decreased**.

- b: Insure that the end of the Suction Wand does not become plugged with foreign material or become blocked by the sides or bottom of the bin.

Note: Large foreign objects entering the wand may plug and damage the Rotary Valve.

- c: Check filter(s) regularly for build up. Clean as required. Restriction of air flow through the filter will reduce capacity. (Item 5, Page 2)

- d: Check the inside of the cyclone periodically for build up on the screen. Simply remove the clamp holding the fan housing and the suction cyclone together. The fan housing is spring loaded and will raise easily out of the way.

Restriction of air flow through the cyclone screen will reduce capacity.



Note: Do not operate the POLYVAC with the fan housing raised. Insure the finger guard is in place at all times. Exposed fan rotor may cause serious injury.

Operation of POLYVAC - SUC Unit

- a: When using the POLYVAC to draw material from gaylords, bins, etc., a certain amount of air is required in the pipe to keep the material fluidized. This secondary air is allowed in by adjusting the air

intake (Item M) on the Suction Wand (Item I) and on the Variable Air Intake (Item F, Page 6).

Initially set both air intakes half way open. No. 5)

Note:

By **closing** the intake, the conveying capacity is **increased**.

By **opening** the intake, the conveying capacity is **decreased**.

- b: Start up the system. Insure that the end of the Suction Wand does not become plugged with foreign material or become blocked by the sides or bottom of the bin.

Note: Large foreign objects entering the wand may plug and damage the Rotary Valve.

- c: With the Suction Wand in the material, adjust the air intake on the wand just to the point where material starts to plug in the flex hose. Now open it up slightly. If more capacity is required adjustments can also be made on the Variable Air Intake.

- d: The variable air intake can be closed slightly, thus reducing the amount of air entering the system at this point.

Caution must be used as closing this intake too much will result in the transfer piping plugging. (ie. not enough air to carry the product) This plug will usually occur at a 90° degree elbow heading vertical.

The amount of secondary air required to enter the system is dependent on the density and size of the particles being transported, along with the piping configuration within the system. Some experimentation will be required for each system to optimize the capacity.

- e: Check the inside of the cyclone periodically for build up on the screen. Simply remove the clamp holding the fan housing and the suction cyclone together. The fan housing is spring loaded and will raise easily out of the way.

Restriction of air flow through the cyclone screen will reduce capacity.



Note: Do not operate the POLYVAC with the fan housing raised. Insure the finger guard is in place at all times. Exposed fan rotor may cause serious injury.

Maintenance

a: **Clean the screen in the cyclone regularly.**

Open the clamp between the fan and the cyclone. Raise the fan housing up. Using an air hose or small brush remove any foreign material from the screen. This material will then be discharged through the rotary valve.



Note: Lock off electrical power before raising the fan housing. Do not operate the unit with the fan housing raised.

b: **Clean or replace the filter sock(s) regularly.**

Tap the filter lightly to remove the dust or material allowing it to fall to the bottom. When the build up of material is sufficient, remove the filter and clean completely.

c: **Check paddle adjustment in the Rotary Valve.**

Paddles should just contact the wall of the rotary valve. If there is a gap between them, loosen the screws and slide the paddle outwards until it contacts the wall. Retighten the screws.

If the paddles are too tight against the wall, the rotary valve will take too much power to operate, or may stop turning altogether.

If there is too much gap between the paddles, on the SUC unit the air pressure used below to convey the material will blow back into the cyclone. This will cause reduced conveying capacity and possible plugging in the transfer lines.

Troubleshooting

Problem	Cause	Remedy
Loss of capacity.	<p>Plugged screen in suction cyclone.</p> <p>Paddles in rotary valve leaking.</p> <p>Motors are rotating in wrong direction.</p> <p>Exhaust filter(s) plugging up.</p>	<p>Clean out screen by means of compressed air and/or steel brush.</p> <p>Loosen the screws and slide the paddle outwards until it contacts wall. Retighten the screws.</p> <p>If paddles must be replaced. Follow instructions in the Rotary Valve manual to remove the cell wheel and install new paddles. At this time the bearings should be checked.</p> <p>Change wiring for motor to run in proper rotation on both the fan and the rotary valve.</p> <p>Clean or replace filter socks.</p>
Rotary Valve not working.	<p>Paddles too tight against housing.</p> <p>Rotor in valve jammed with foreign material.</p> <p>Rotor bearings seized.</p>	<p>Loosen the screws and slide the paddle away from the housing. Paddles should just contact the wall. Retighten the screws.</p> <p>Loosen the clamp between the fan housing (Item H, Page 2) and the cyclone (Item A) and raise the fan housing up. Loosen the clamp on the bottom of the cyclone and remove the cyclone. The rotary valve is now exposed. Remove any foreign material blocking or plugging the valve.</p> <p>Remove the end caps and replace as outlined in the Rotary Valve service manual.</p>
Plugging of pressure line - (SUC Unit).	Not enough air being introduced to convey material when going into 6" line from 4" suction line.	Open the Variable Air Intake (Item F, Page 6) until material flows freely.

Dimensions

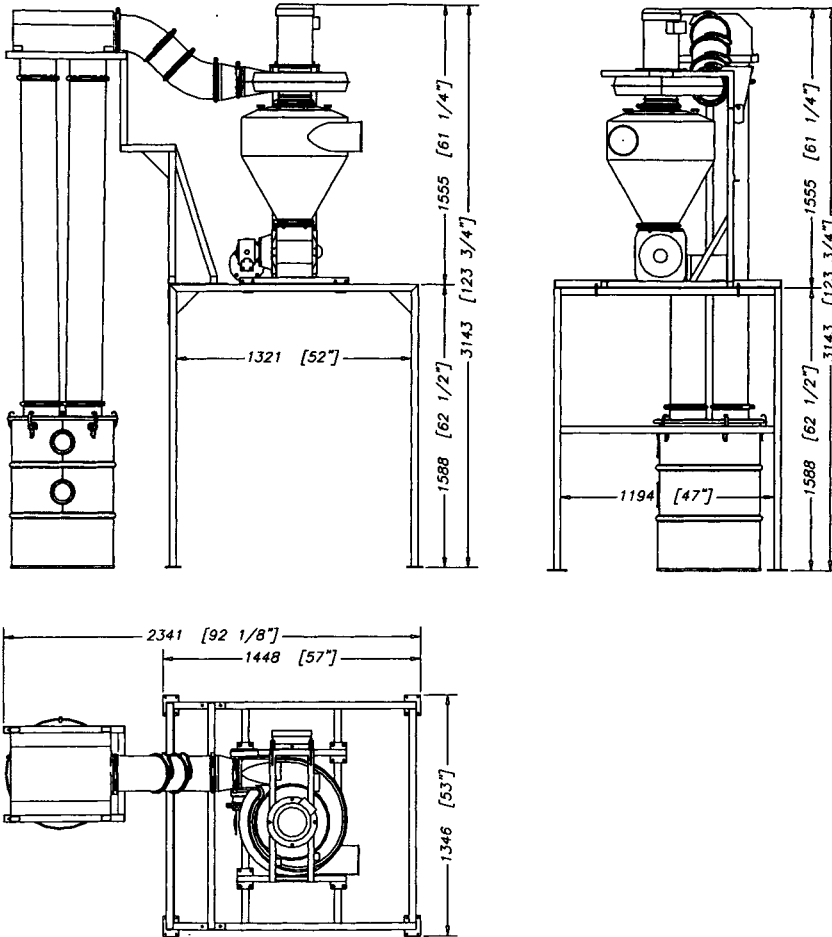

Specifications

Model	30	50
Motor	3 hp 3.600 rpm	5 hp 3.600 rpm
Frame	182T	184T
Phase	3	3
Voltage	460/575	460/575
Fan Rotor	3.600 rpm 360 mm dia. on one stage centrifugal	3.600 rpm 415 mm dia. on one stage centrifugal
Weight w/o motor and rotary valve	80 lbs	100 lbs
Rotary valve type	RF 20	RF 20
Rotary valve Motor	0.5 hp 1.800 rpm	0.5 hp 1.800 rpm
Hose & Nozzles	4" Poly	4" Poly

EC Declaration of Conformity

Kongskilde Industries A/S, DK-4180 Sorø, Denmark, hereby declares that:

Kongskilde suction blowers type PolyVac

Are produced in conformity with the following EC-directives:

- Machinery Directive 2006/42/EC
- Electro Magnetic Compatibility Directive 2014/30/EC
- Low Voltage Directive 2014/35/EC

Kongskilde Industries A/S
Sorø 01.03.2023



Jeppe Lund
CEO

Kongskilde Industries A/S

Skælskørvej 64

DK - 4180 Sorø

Tel. +45 72 17 60 00

mail@kongskilde-industries.com

www.kongskilde-industries.com