

MultiCutter MCB 100/160/180/200

Data sheet

The MCB MultiCutters are unique inline cutting units to cut endless and continuous residual materials into smaller pieces. All cutters can be integrated into new or existing waste extraction systems.

MCB MultiCutters are unique inline cutters designed to seamlessly integrate into existing waste extraction systems. They offer solutions for numerous applications, efficiently cutting a wide variety of materials with minimal air resistance, high throughput rates, and exceptional reliability.

The MCB 100, 160, 180, and 200 cutters are specifically engineered for cutting production waste. The cutter is equipped with 2 or 3 rotating knives, and a fixed blade. These versatile units can handle various residual materials from production processes, such as edge strips and stamped grids, within pipe systems.

Materials that can be cut include:

- Self-adhesive materials including labels
- Various types of cardboard
- Packaging materials
- Wood veneers
- Synthetic materials (plastics)
- Paper
- Textiles
- Foils
- Additional materials upon request

Benefits

- **High Reduction of Waste Volume:** Effectively decreases the volume of production waste
- **Versatile Cutting Capability:** Capable of cutting a wide range of materials.
- **Compact Design:** Optimised for space-saving installation.
- **Genuine Scissor-Knife Cut:** Ensures precise and clean cuts while minimizing dust.
- **Low Noise:** Scissor cut principle assures low noise during operation.
- **High Throughput:** Maintains high processing speeds.
- **Low Energy Consumption:** Energy-efficient operation.
- **Low Air Resistance:** Minimizes impact on airflow within extraction systems.
- **Low Operation Costs:** Cost-effective maintenance and operation.
- **Flexible placement:** Cutter can be mounted in any direction.



Dimensions

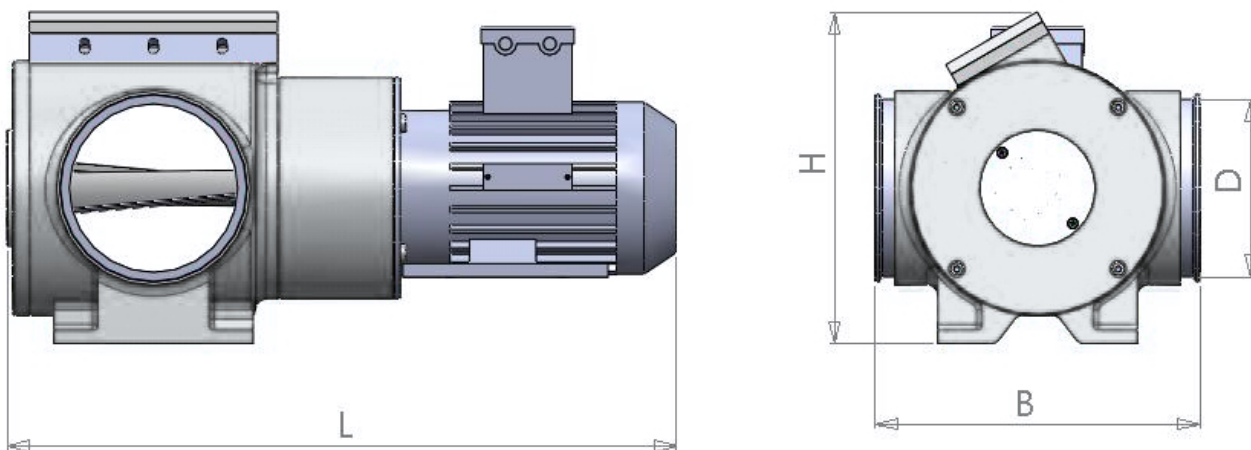

Type	D (mm)	L (mm)	B (mm)	H (mm)	Weight (kg) incl. motor
MCB-100	100	392	254	198	22
MCB-160	160	517	284	208	34
MCB-180	160	655	293	300	65
MCB-200	200	720	350	310	80

Versions Available

All cutters are fully certified to meet international safety standards, including CE, UL, and CSA certifications.

Model	Inlet & Outlet	Knives	Power kW (50Hz / 60Hz)	RPM (50Hz / 60Hz)
Cutter MCB-100	100mm	2 knives	0.55 / 0.66	1500 / 1800
Cutter MCB-100	100mm	2 knives	0.55 / 0.66	3000 / 3300
Cutter MCB-100	100mm	3 knives	0.55 / 0.66	1500 / 1800
Cutter MCB-100	100mm	3 knives	0.55 / 0.66	3000 / 3300
Cutter MCB-160	160mm	2 knives	0.75 / 0.9	1500 / 1800
Cutter MCB-160	160mm	2 knives	0.75 / 0.9	3000 / 3300
Cutter MCB-160	160mm	3 knives	0.75 / 0.9	1500 / 1800
Cutter MCB-160	160mm	3 knives	0.75 / 0.9	3000 / 3300
Cutter MCB-180	160mm	2 knives	0.75 / 0.9	1500 / 1800
Cutter MCB-180	160mm	2 knives	0.75 / 0.9	3000 / 3300
Cutter MCB-180	160mm	3 knives	0.75 / 0.9	1500 / 1800
Cutter MCB-180	160mm	3 knives	0.75 / 0.9	3000 / 3300
Cutter MCB-200	200mm	2 knives	1.5 / 1.8	1500 / 1800
Cutter MCB-200	200mm	3 knives	1.5 / 1.8	1500 / 1800

Material Thickness

Type	Paper / Cardboard	Plastic / Soft Flexible	Aluminum Foil
MCB 100	40-120 g/m ²	40-150 µm	40-80 µm
MCB 160	40-400 g/m ²	40-400 µm	40-150 µm
MCB 180	40-400 g/m ²	40-400 µm	40-150 µm
MCB 200	40-600 g/m ²	40-500 µm	40-300 µm

Backpressure Curves

MCB-100

Comparison of backpressure curves for MCB-100 with 2 and 3 knives.

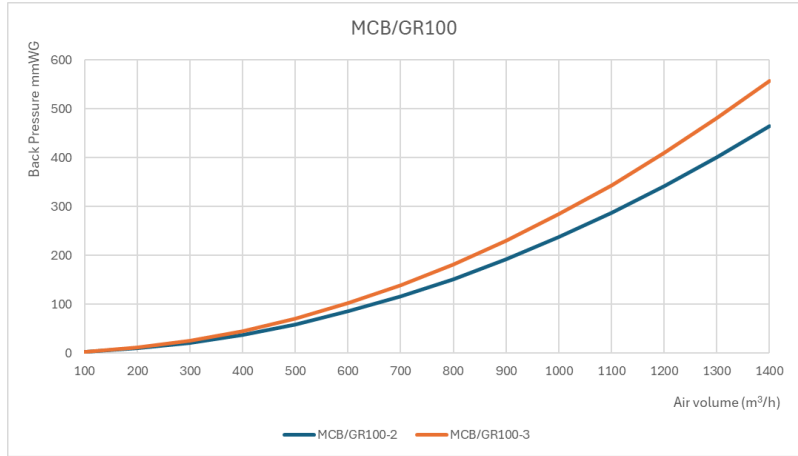

MCB-160

Comparison of backpressure curves for MCB-160 with 2 and 3 knives.

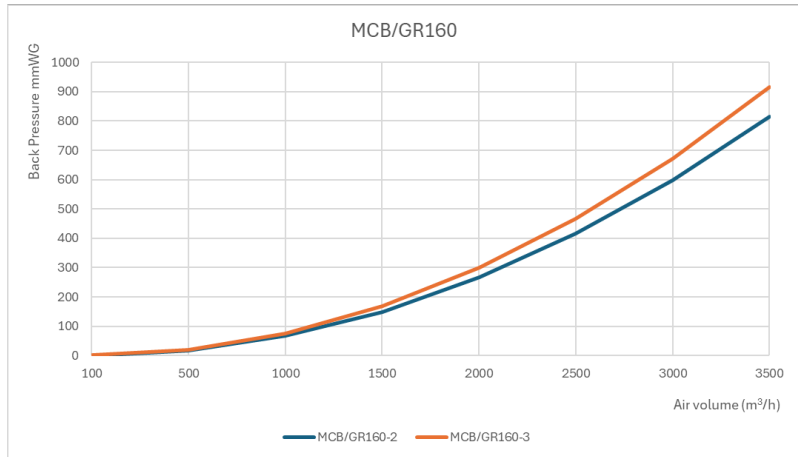

MCB-180

Comparison of backpressure curves for MCB-180 with 2 and 3 knives.

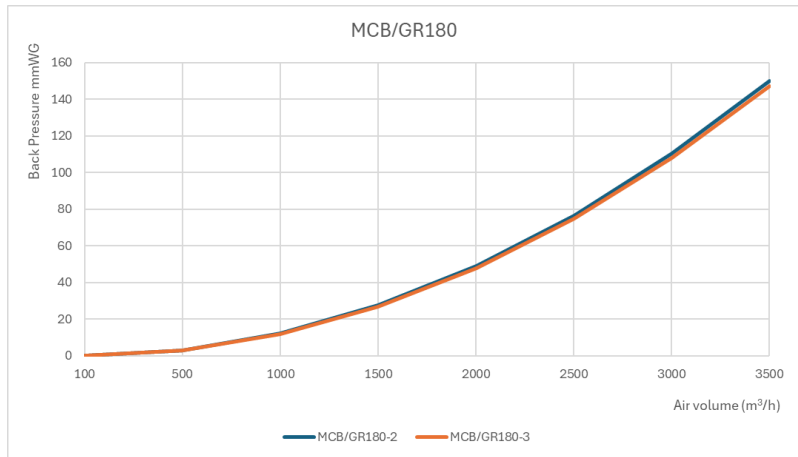

MCB-200

Comparison of backpressure curves for MCB-200 with 2 and 3 knives.

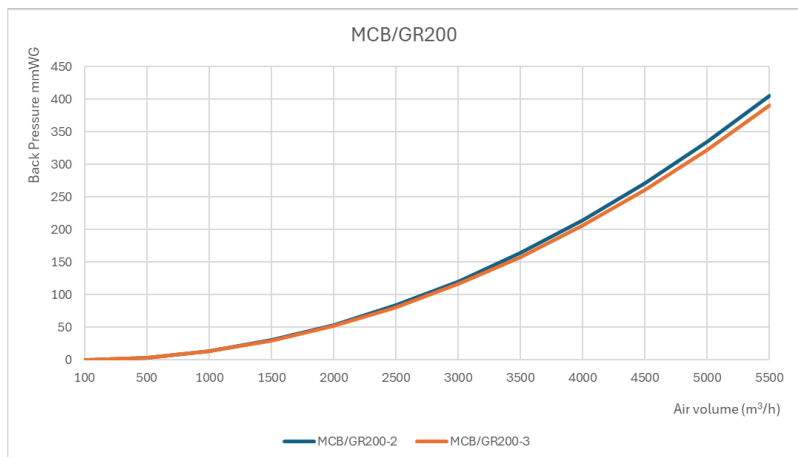

Cutter Orientation Options

Save Space

Our versatile cutter is designed to accommodate virtually any mounting orientation. Whether you need to position it horizontally or vertically, the cutter will perform reliably and efficiently. This flexibility allows you to optimize your workspace, saving valuable space while maintaining functionality.

