

Compact Unit CUB-Series

Data sheet

The Kongskilde CUB-1600 is a flexible, compact unit designed to handle endless trim, self-adhesive matrix, and other waste from one or multiple machines.

The CUB-1600 is a compact unit designed to handle trim waste directly from production machines. An integrated cutting module reduces the volume of waste, while the system transports trim up to 35 m³ and disposes of it into a bag, an endless bag, or compacts it for direct disposal into a bin.

Models and Versions

The CUB-1600 is available in two power models: 2 kW or 4 kW. Each model comes in three standard versions:

- Basic – the standard solution for general applications
- Antistatic – designed for handling static materials
- Non-stick – designed for labels and other sticky materials²

Quiet and Clean Performance

The CUB-1600 is built with large silencers inside a sealed steel enclosure, ensuring low-noise performance suitable for placement within the production environment. Clean exhaust air is returned to the production through a built-in F7 dust filter, with the option to upgrade to a HEPA filter kit.³

Extended Waste Handling - Bag Collection

The CUB-1600 comes with a 900-litre bag that provides long running times between changes. For greater efficiency, an endless bag kit is available as an accessory. Waste can be pulled away, sealed with two cable ties, and cut to continue operation with minimal interruption.

Unlimited Capacity - Waste Screw Compactor

The Kongskilde Screw Compactor provides continuous, hands-free waste handling with unlimited capacity. It cuts and compacts material for easy disposal, delivering continuous operation, greater efficiency, and uninterrupted production.

Simple, Intuitive Controls

Operation is straightforward with no PLC or HMI required. Simple push buttons and a speed dial allow easy, precise control of the unit without unnecessary complexity.

Flexible Mobility

With a width of just 800 mm and a height of 2,150 mm, the CUB-1600 can pass through most factory doors. Its sleek design allows easy movement within production facilities using a forklift or pallet jack.

Accessories

- Endless bag kit, for extended operation.
- Screw compactor, for continuous operation.
- Oil mist system, for trim handling with glue.
- Antistatic kit, for trim with high static charges.
- HEPA filtration kit, for even better return air filtration.
- Level sensor with light tower kit.

Features & Benefits

- Cost-effective system for cutting and extraction in one unit.
- High uptime with low maintenance needs for reliable, continuous operation.
- Size reduction of waste volume.
- Low energy consumption due to an energy-efficient blower.
- Extraction of the cut material through the blower.
- Compact, mobile design with a small footprint for flexible placement.
- Low noise levels due to modern pipe silencers.



CUB with Waste Screw Compactor

¹ Depending on amounts of bends and material.

² Non-stick unit only available as 4 kW.

³ Local laws can forbid circulation of production air back into the production environment.

Technical Data

Technical Specifications	CUB-1620	CUB-1640
Material thickness	40 - 300 µm	40 - 300 µm
Blower max. power consumption	2.2 kW	4.0 kW
Cutter power consumption	0.75 kW / 1,500 rpm	0.75 kW / 1,500 rpm
Power supply	CE: 3 x 400V - 50 Hz, 16A UL/CSA: 3 x 460V - 60 Hz, 16A	CE: 3 x 400V - 50 Hz, 16A UL/CSA: 3 x 460V - 60 Hz, 16A
Weight, kg	400	400
Size (height x width x length)	2,150 x 800 x 1,570 mm	2,150 x 800 x 1,570 mm
Pipe connection at inlet	OK 160	OK 160
Noise level	Max. 80 dBa excl. material	Max. 80 dBa excl. material
Compressed air supply for oil system	Min. 4 bar - Max. 6 bar. Consumption: 200 l/hour	Min. 4 bar - Max. 6 bar. Consumption: 200 l/hour

Screw Compactor Option

The Kongskilde Screw Compactor integrates with the CUB for continuous, hands-free waste handling. An electric motor drives the screw against an adjustable, air-controlled compression plate to suit different materials and compaction levels. With an optional stand, material can be discharged directly into a container. The compactor handles various waste such as plastic, paper, cardboard, foil, or labels, including static or adhesive materials.

Technical Specifications	Waste Screw Compactor
Material thickness	40 - 300 µm
Power consumption	3 kW / 1,500 rpm
Power supply	CE 3 x 400V - 50Hz - 16A UL/CSA 3 x 460V - 60Hz - 16A
Weight, kg	340
Size (Height x Width x Length)	1,630 x 450 x 1,890 mm
Compressed air supply	Min. 1 bar - Max 8 bar
Capacity	Maximum 50 m³/h
Screw rpm	38 rpm

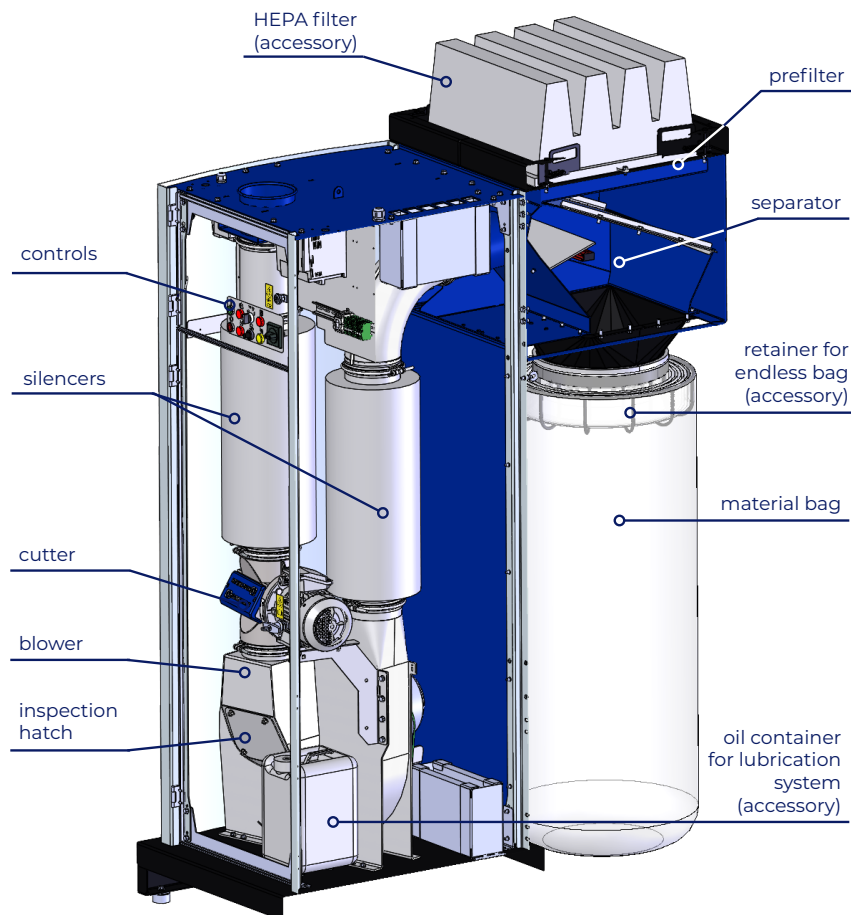

Capacity with Bag Solution

Operation Times

WITH ONE TRIM:

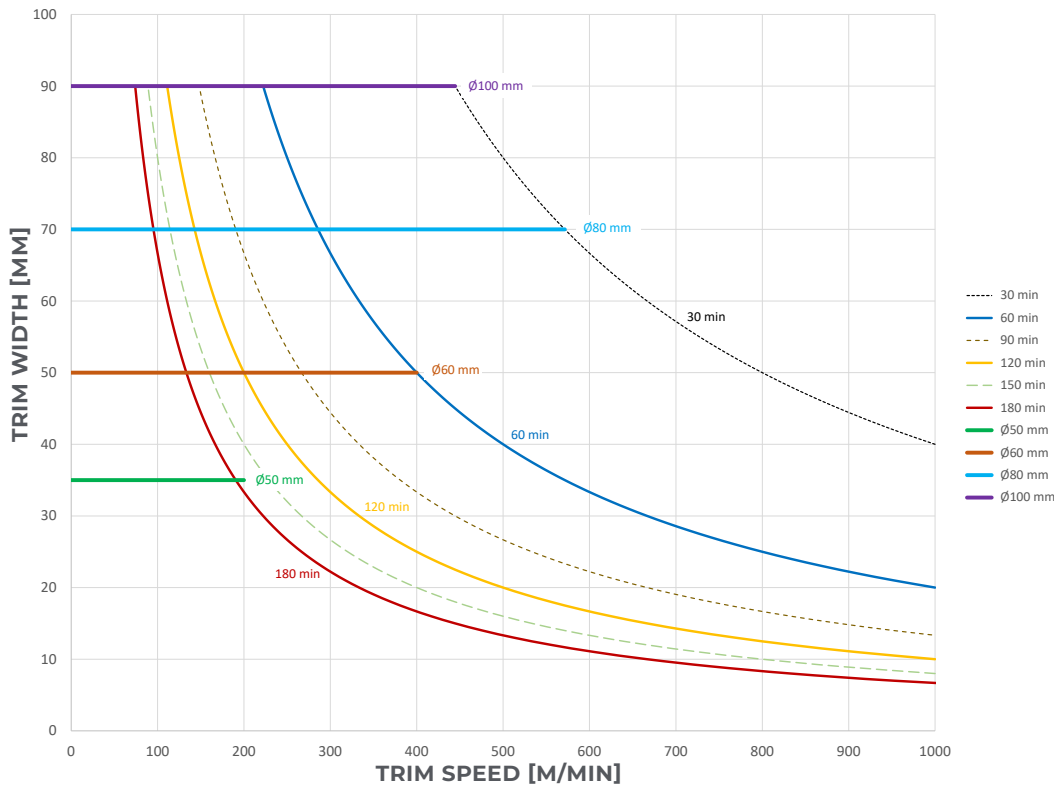

The diagram illustrates that transporting one 70 mm strip requires a Ø80 mm pipe, etc.

WITH TWO TRIMS:

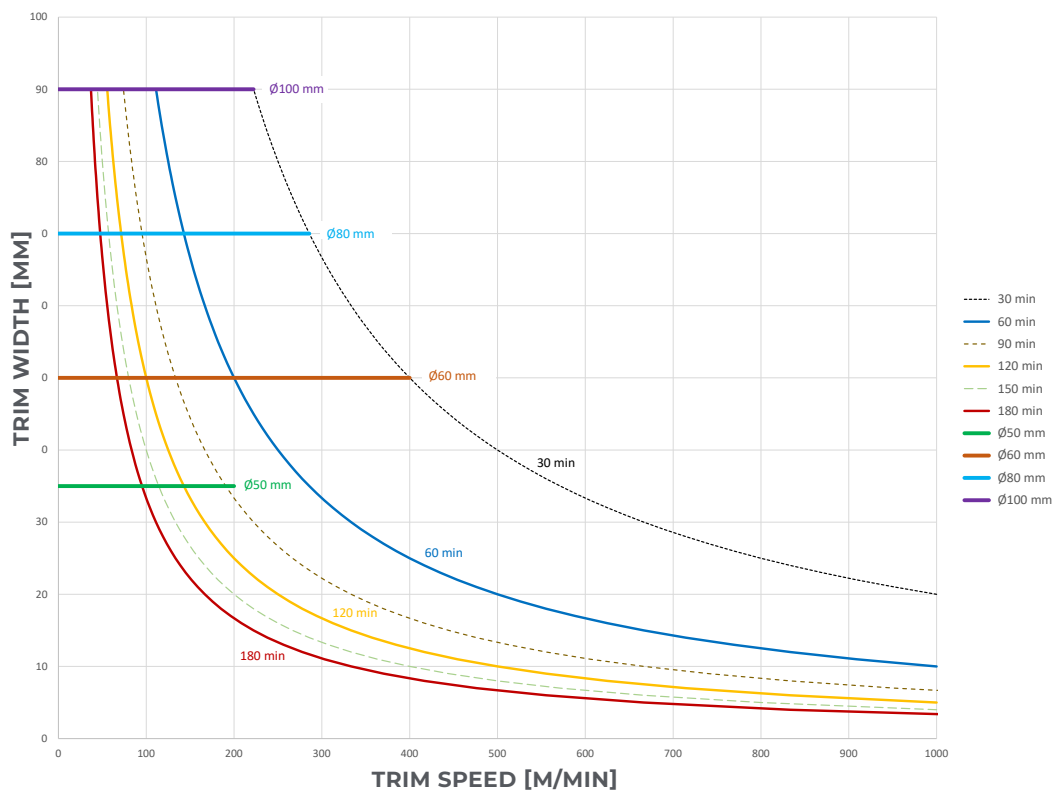

The diagram illustrates that transporting two 70 mm strips requires a Ø80 mm pipe, etc.

Dimensions

Standard CUB Unit

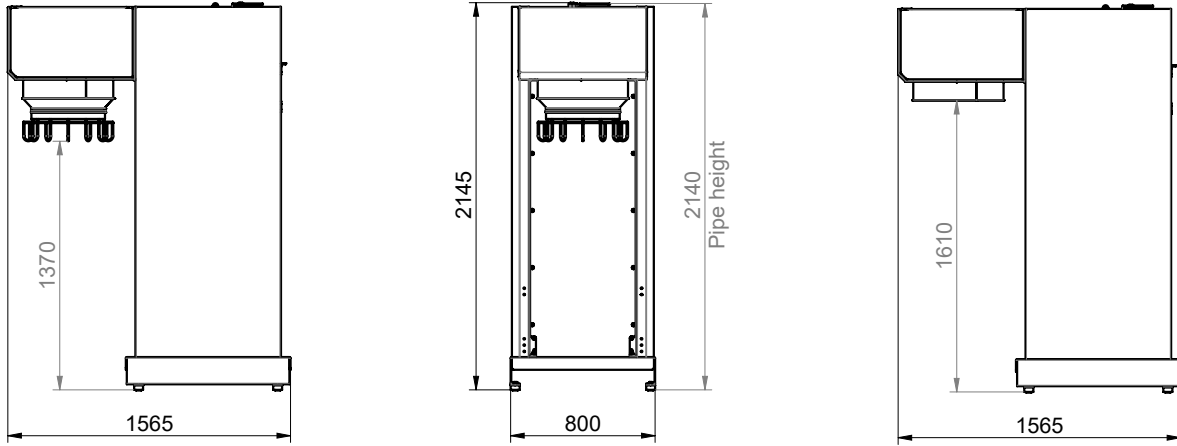

CUB Unit with Waste Screw Compactor

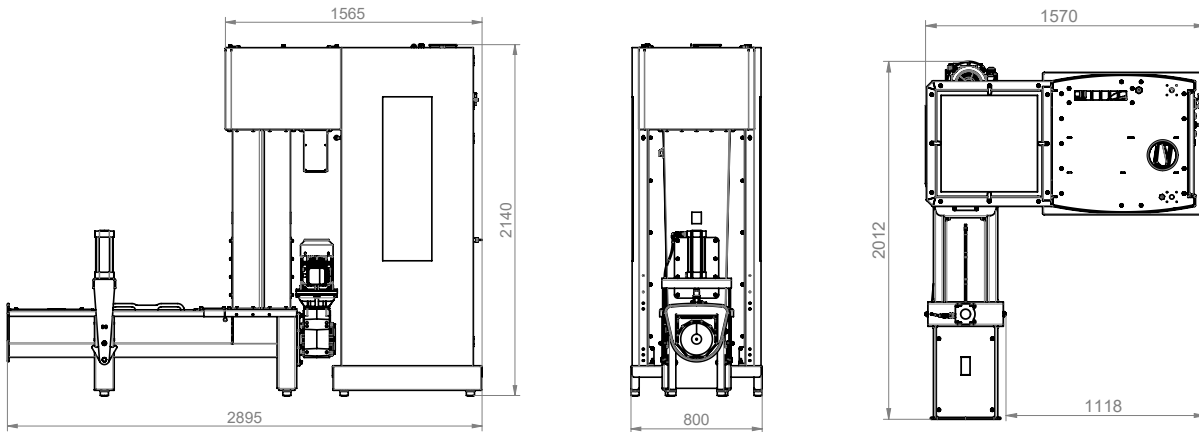

Compactor Stand Height Options

