

MultiAir® 4000

Data sheet

The MultiAir is used in connection with other Kongskilde equipment to convey products from the plastic, packaging, and printing industries.

The Kongskilde range of high-pressure MultiAir® blowers is specifically designed as an integral part of the Kongskilde pneumatic conveying range of equipment. The MultiAir is used in connection with other Kongskilde equipment in order to convey products from the plastic, packaging, and printing industries.

The MultiAir® 4000 series is a new generation of high efficiency high-pressure blowers, which are very reliable, save power, have low noise levels and low maintenance.

As standard, the MultiAir® 4000 series is equipped with the same type of control with frequency converter as the MultiAir® FC 2000 series.

The new MultiAir® FC 4000 series of blowers are available in two product ranges, each with different motor sizes. One range is a high-efficient clean air blower, which can be used in systems for handling of air not containing material. These blowers carry a "P" (Particles).

The range consists of five different models:

- MultiAir® FC 4220P
- MultiAir® FC 4300P
- MultiAir® FC 4370P
- MultiAir® FC 4450P
- MultiAir® FC 4550P

The other range allows material to pass through the blower. These materials should be light materials in smaller pieces, such as paper and plastic foil downsized to max. 100 x 100 mm. Granules from a grinder and other similar materials can also pass through the blower. Be aware that this type of material can be abrasive and wear on the blower parts, which then need to be regularly maintained.

The "M" (Material) range consists of these five models:

- MultiAir® FC 4220M
- MultiAir® FC 4300M
- MultiAir® FC 4370M
- MultiAir® FC 4450M
- MultiAir® FC 4550M

The MultiAir FC blowers have many advantages compared to the traditional blower type:

Powersaving. The FC blower is adjusted to perform exactly to the required extent without running with overcapacity and thus prevents use of unnecessary power.

The suction power can be adjusted to handle different types of materials, thicknesses, and speeds. The volume of air extracted from the production area is minimized, which saves power to the air conditioning.

Lifetime is extended on blower components, because they are not loaded 100% all the time.

Avoidance of unnecessary additional noise, as the system runs without overcapacity.

Compact design which requires a minimum of space for installation.

The control system facilitates remote operation and control of other electrical components in the pneumatic system solution, such as cutter motor or separator.



Technical Data

The MultiAir® 4000 series are performance tested and fulfill the demands of the international regulation of ecodesign for electric fans (EU) No 327/2011 for high accuracy on performance data.

All blowers supplied within the EU used for moving clean air must follow this regulation (not required for pneumatic conveying). The machine sign informs about this.

The MultiAir® 4000 blowers are available in a version with open inlet. If the blower is used in a pressure system, it is necessary to connect a silencer to the inlet of the blower.

	Common Properties
Power supply - MA FC/FCE 4000	380 - 480 V, 50/60 Hz
Approvals - MA FC/FCE 4000	CE or UL/CSA
Power supply - MA 4000	380 - 415 V, 50 Hz or 440 - 480 V, 60 Hz
Approvals - MA 4000	CE and UL listed components
Max. heating of air - P (clean air) blowers	Max. 21°C
Rotor rpm at full performance	3,600 rpm
Wall thickness of inlet pipe	FK350, min. 1.25 mm (Min. 1.5 mm for FC / FCE / MA 4550)
Ambient temperature - FC4000	-10°C to 50°C
Ambient temperature - MA4000	-30°C to 50°C
Sound pressure level Lp (1 meter)	Max. 80 dB (A) *

*: Exclusive noise from piping. If the overall installation is not adequately attenuated, high noise levels may occur.

MultiAir type	MA FC/FCE 4220	MA FC/FCE 4300	MA FC/FCE 4370	MA FC/FCE 4450	MA FC/FCE 4550
Nominal motor power (kW)	22	30	37	45	55
Fuse rating CE (Ampere)	80	90	90	100	125
Fuse rating UL/CSA (Ampere)	80	90	90 (FCE 100)	100	125
Weight FC (kg)	1,000	1,050	1,100	1,100	1,100
Weight FCE (kg) excl. control cabinet	970	1,000	1,000	1,030	1,050

MultiAir type		MA 4300	MA 4370	MA 4450	MA 4550
Frequency converter output max. (kW)		22	30	45	55
Nominal motor power (kW) at 50Hz		30	37	45	55
Nominal motor power (kW) at 60Hz		34	42	52	63
Fuse rating (Ampere)		50	63	80	100
Weight (kg)		970	1,000	1,030	1,050

The following applies to the material blowers:

Material types - see section "Description"

Max. divided material weight	20 gram
Max. dimension for solid materials	10x10x10 mm
Max. dimension for flexible materials (trim and off-cuts) - diagonal dimension *	200 mm

* Materials must not be sticky or damp. For plastic and metal foil over 0.5mm thickness, the corresponding diagonal measurement will be 150 mm.

Capacity

MultiAir® FC/FCE 4000 P

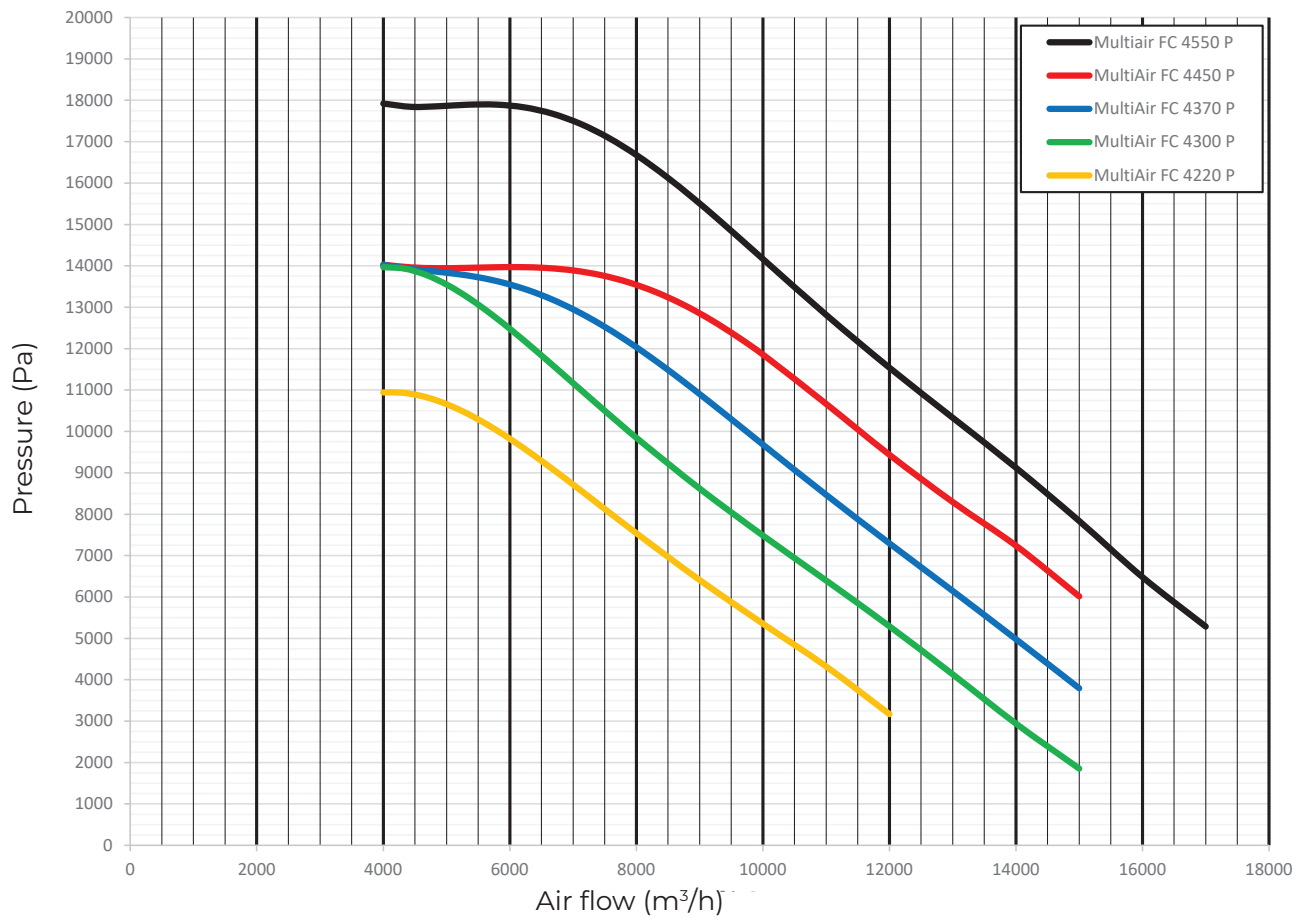

MultiAir® FC/FCE 4000 M

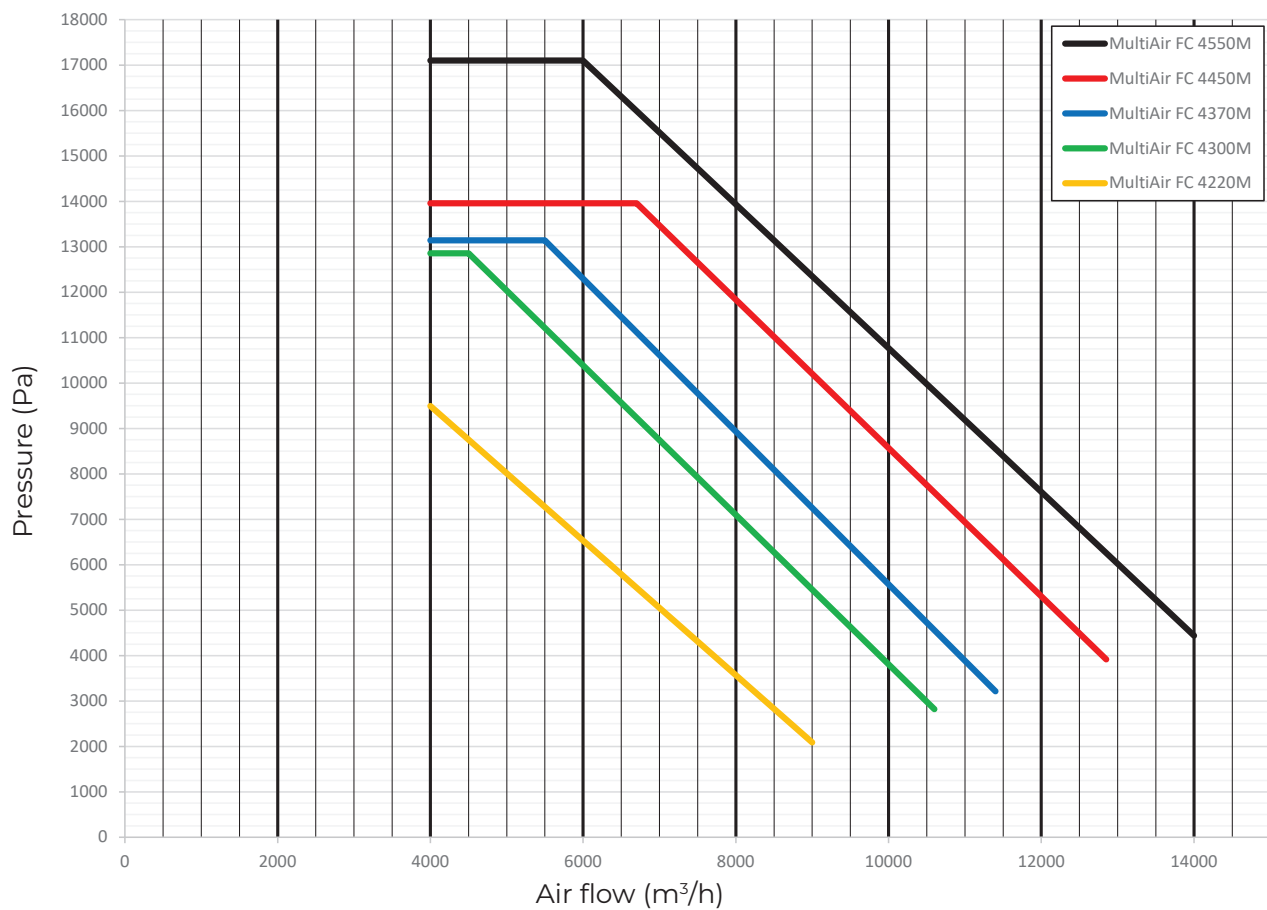

Capacity

MultiAir® MA 4000 P

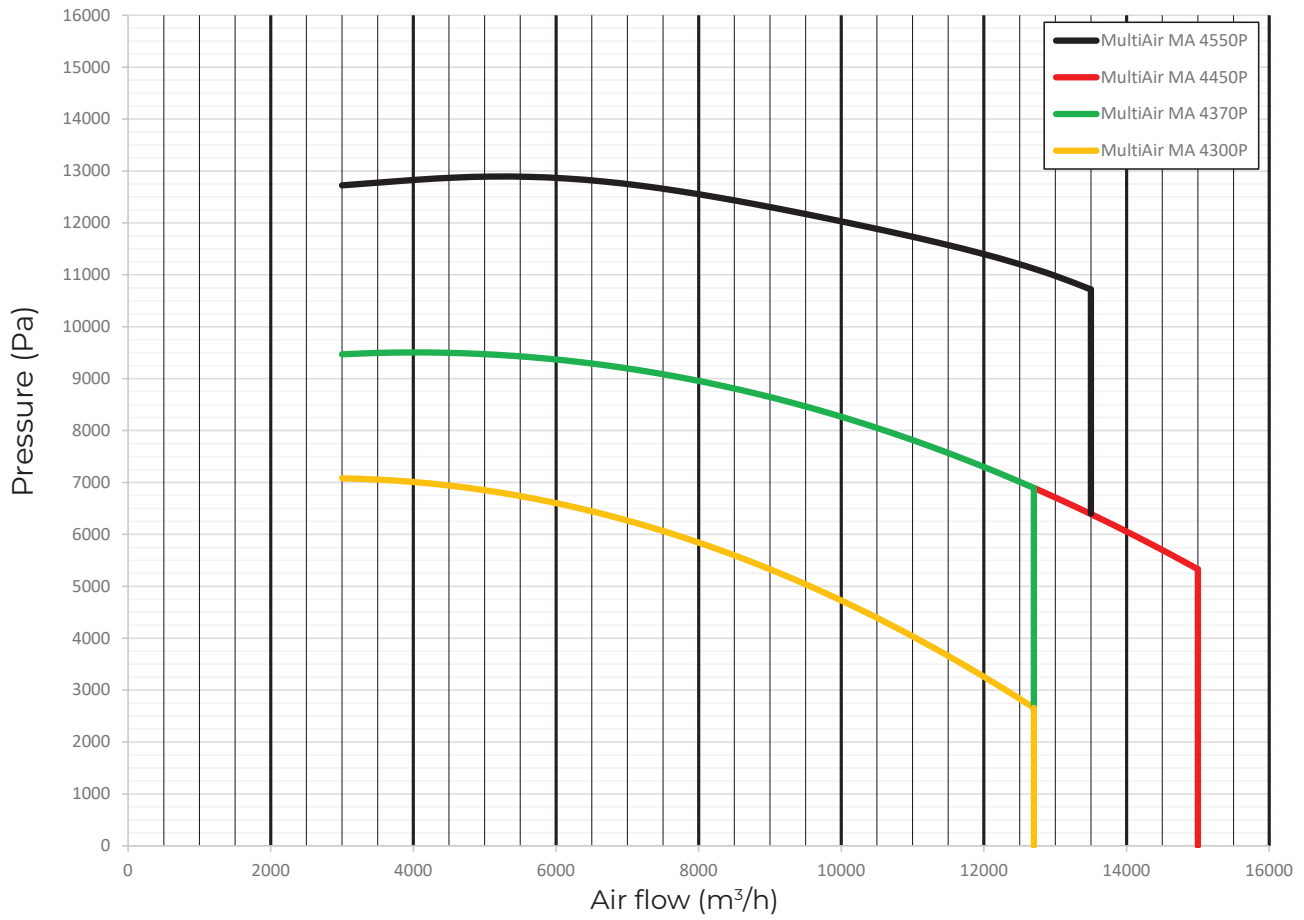

MultiAir® MA 4000 M

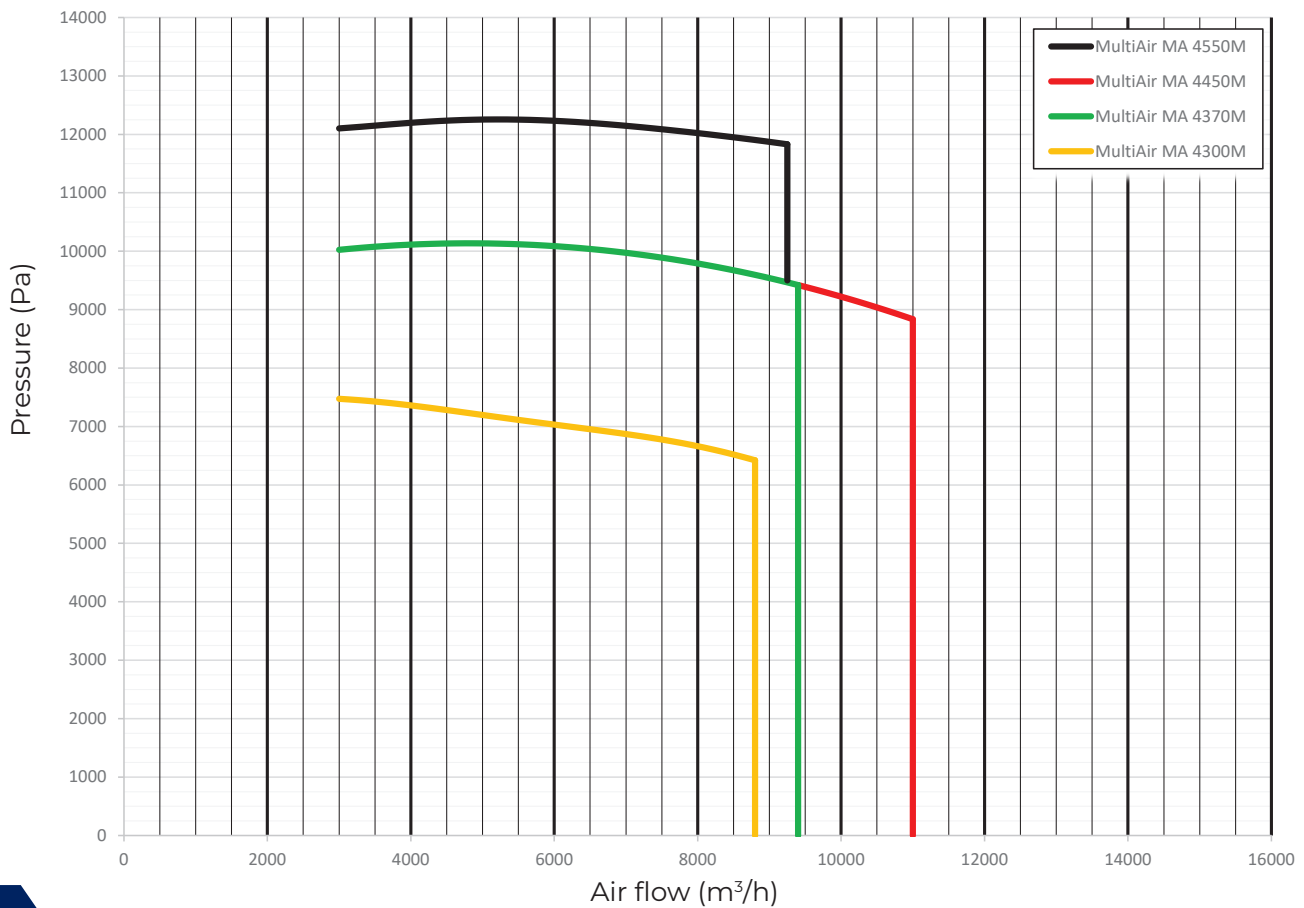

Control System

The manual control of the MultiAir 4000 series is easily done via the operators' panel.

If the blower is connected to optional automatic performance control or linked up to external motors, the operator's panel is used to set the programming.

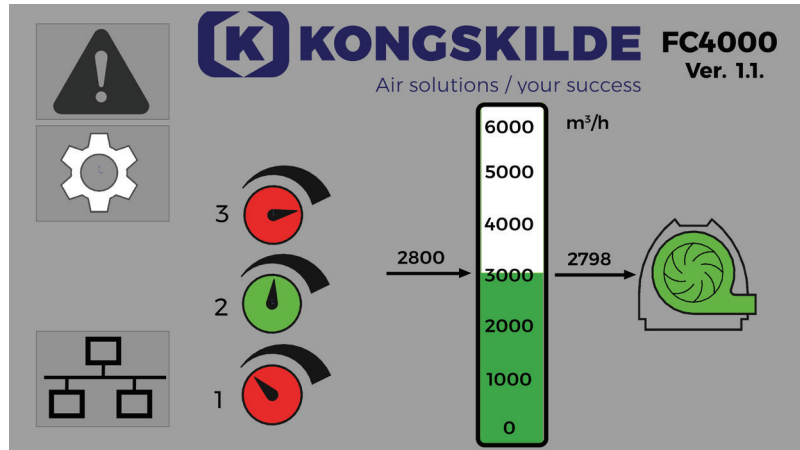

Up to three setpoints can be pre-programmed into the panel. These set points can be adapted to different typical situations for required suction capacity in the production facility in question.

If for instance a plant has three production machines demanding periodical suction of waste material, the three set points can be pre-programmed to adapt to suction from 1, 2, or 3 machines.

Switching between the three setpoints can be done remotely via a digital signal.

The same feature can also effectively be used in connection with a converting machine. These machines often run with different materials demanding different levels of suction power to evacuate trim. In these cases, the presettings can be used to adapt suction capacity to the different types of material.

On the display, the actual running data can be chosen to be seen in either blower RPM, air flow, or pressure.



The operator's panel is placed either inside the blower casing or outside for easy access.

Automatic Control of Blower Performance

To minimize power consumption you can connect the MultiAir FC 4000 with either a pressure control or an air flow control, which in combination with the built-in MultiAir control panel can adjust the output of the blower automatically to meet specific requirements.

The MultiAir FC 4000 series has facilities built into the control which allow for connection of external sensor systems.

Pressure Control

Example: One MultiAir connected to a RVS extracts waste trim from three machines: In case one or two of the machines are not running, thus the air extraction from these are closed. An unregulated blower will automatically increase the suction from the one or two machines still in operation to an unnecessarily high level. This leads to unnecessary power consumption and extraction of conditioned air.

By installing the pressure control to manage the blower performance, the blower will automatically adjust to the required performance and thereby saving power and reducing extraction of conditioned air.

The shutter and the cutter can be operated remotely from the production machine, eg. a converting machine, in such a way that the cutter is not running, and the suction is closed when the machine does not run.

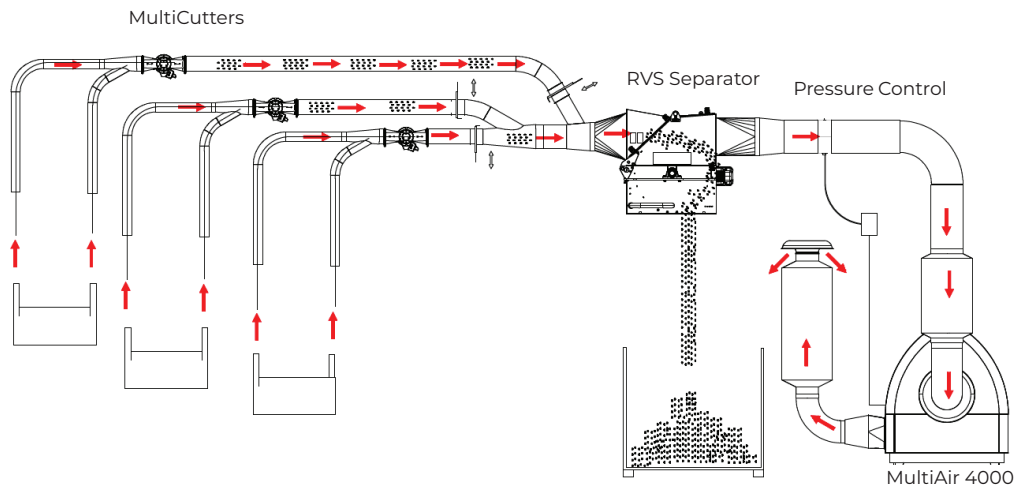

Air Flow Control

Air flow control is used in systems where a constant air flow is required, eg. in pneumatic conveying systems.

An example could be a system where conveyed material must be delivered at different destinations.

Another example could be a system, where material is extracted from a production machine which processes different materials. The waste material must be kept separated in two fractions. The conveying distance for each fraction is not the same.

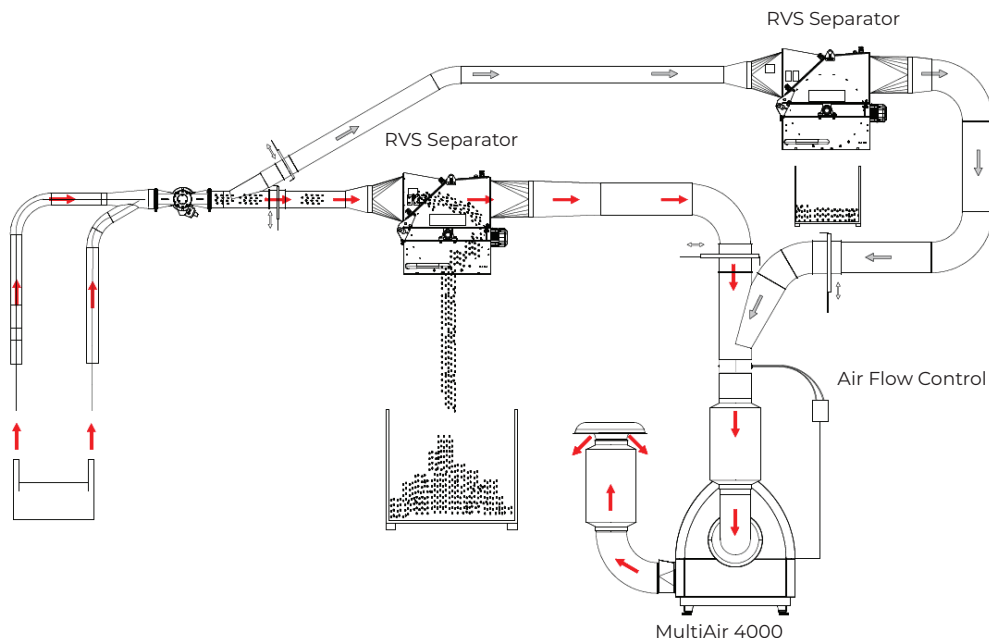

Pressure Regulation



Components for measuring of pressure in the pipe:
A short pipe installed in the pipeline is connected to the electric transmitter box with a hose.

The electric box supplies a 4 – 20 mA signal to the MultiAir control box, which ensures that the blower's performance adapts to the required level.

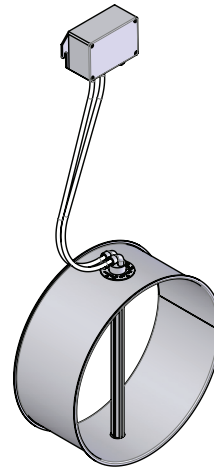

Components for measuring of air flow in the pipe:
A short pipe installed in the pipeline is connected to the electric transmitter box with two hoses.

The pressure difference between the two measuring points in the pipe is transmitted by an electrical signal supplied via cable to the control box in the MultiAir.

The pressure difference between the measuring points depends on the air flow in the pipe.

The control panel in the MultiAir adjusts the air flow from the blower to meet the required level.

External Motor Control

The operator's panel in the MultiAir can control start/stop of up to two external motors.

The blower supplies a 24 VDC signal as input to the external motor controls. On the MultiAir panel, start and stop sequences can be programmed to secure start and stop of the system without blockage.

The below list of optional external motor controls are available.

MultiAir® 4000 Motor Control	Adapts to motor 3 x 400 V 50 Hz
External control 1.0 - 1.3 A, 3 x 200 - 600 V, 50/60Hz	0.37 kW
External control 1.3 - 1.7 A, 3 x 200 - 600 V, 50/60Hz	0.55 kW
External control 1.7 - 2.3 A, 3 x 200 - 600 V, 50/60Hz	0.75 kW
External control 2.3 - 3.1 A, 3 x 200 - 600 V, 50/60Hz	1.1 kW
External control 3.1 - 4.2 A, 3 x 200 - 600 V, 50/60Hz	1.5 kW
External control 4.2 - 5.7 A, 3 x 200 - 600 V, 50/60Hz	2.2 kW
External control 5.7 - 7.6 A, 3 x 200 - 600 V, 50/60Hz	3.0 kW
External control 7.6 - 10 A, 3 x 200 - 600 V, 50/60Hz	4.0 kW

The controls meet the demand of IEC/EN and UL/CSA approvals.

Dimensions

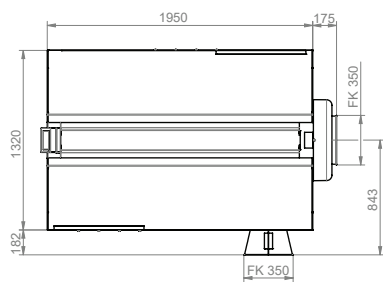
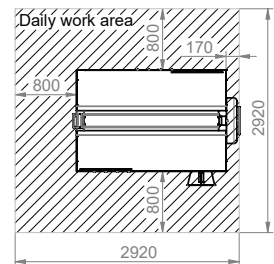
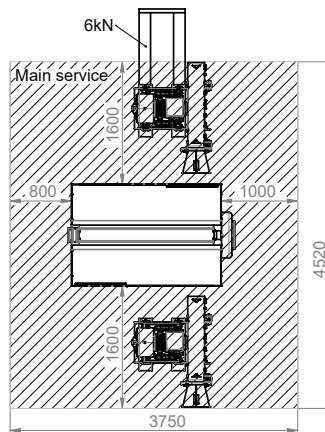
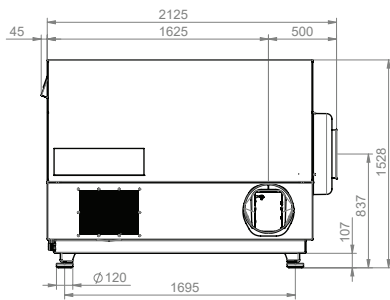
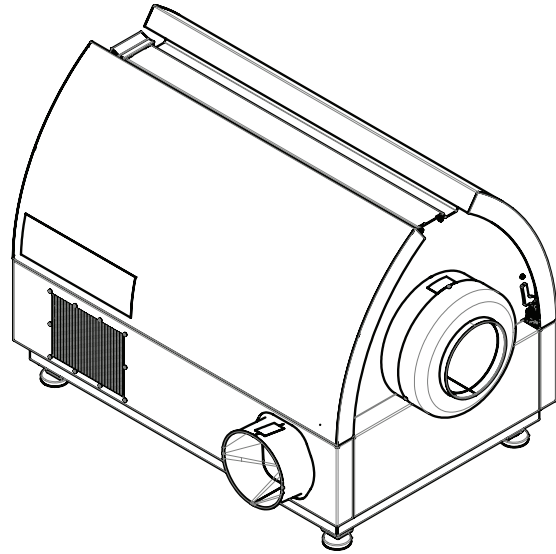
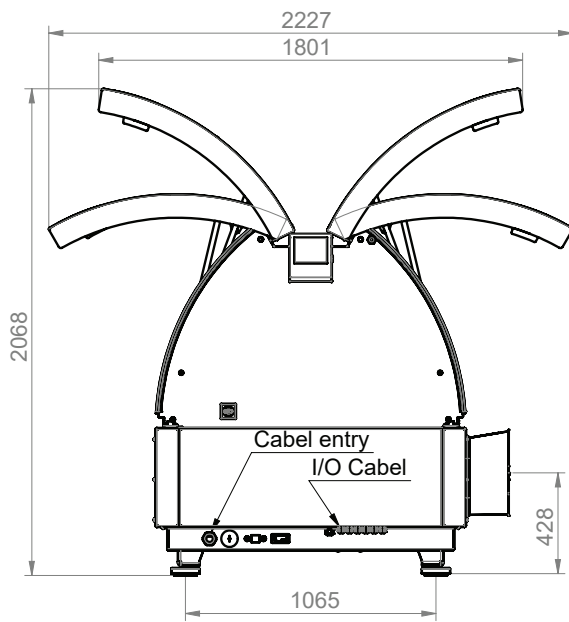

123002140 EXP/GB/MultiAir-4000/DATA/0626

Subject to change without notice.

Kongskilde Industries A/S

Tel.: +45 72 17 60 50

industry@kongskilde-industries.com

www.kongskilde-industries.com

