

# Compact Unit CUC-series

## Data sheet

The Kongskilde Compact Unit is an All-In-One solution for trim handling.

The Kongskilde Compact Unit is a flexible, standalone solution for your trim handling needs.

The unit handles endless trim of paper, carton, and plastic/metal foils, or cut trim - without the need for a cutter or anti-static equipment - for less maintenance and more production uptime.

The noise level is low due to a large silencer and an internal filtration system, even at max. performance.

The filtration consists of a pre-filter and a HEPA filter. Both filters are easily accessible and maintainable.

With the low noise level and filtration system the Kongskilde Compact Unit is suitable for most production areas<sup>1</sup> and is easily moved to adapt to the production facilities.

The unit is a flexible solution in a compact design, and it passes through a standard industry door. It is designed to be moved by a pallet jack or forklift.

The built-in frequency converter ensures maximum flexibility, as the Compact Unit is adjustable up to 4750 Pa, and is well suited for many different applications.

The built-in compactor ensures optimal compression of the material, as the compression force is adjustable according to material specifications and process requirements. It is possible to mount an endless bag on the outlet of the compactor.

### Footprint:

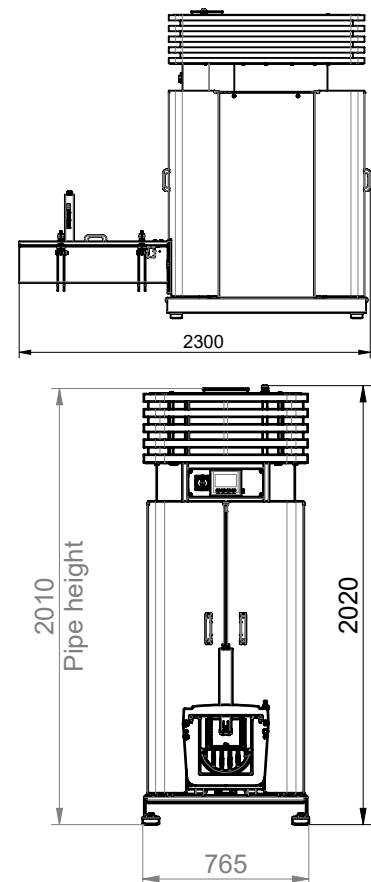
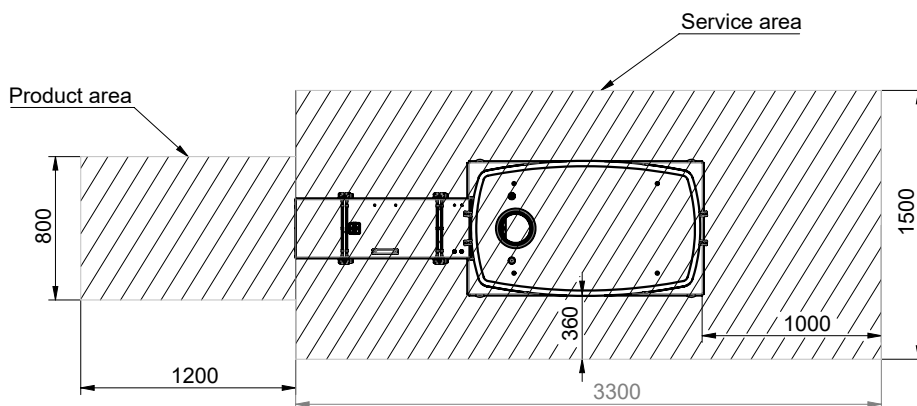

<sup>1</sup> Local regulations may prohibit air return to the production area.

# Compact Unit Specifications

Unit type	CUC 1020/1320/1620
Air/material Inlet	OK 100/125/160
Dimensions LxWxH (mm)	2300x765x2010
Power input (V/Hz)	3x400V, 50/60Hz, 16A
Power consumption (kW)	4
Max. air pressure (Pa)	4750
Material thickness (µm)	8-150*
Material amount (m <sup>2</sup> /min.)	Up to 80
Compressed air supply (bar)	Min. 6, max. 10
Compressed air (l/min.)	175
Max. noise level (dBa)	80
Weight (kg)	700
Pre-filter	F7
Filter	HEPA cassette H14 (or similar)

\*Material specifications are to be evaluated in each case based on thickness, material elasticity, and volume.

## Performance Curves

Compact Unit CUC 1620 with pre-filter and HEPA filter

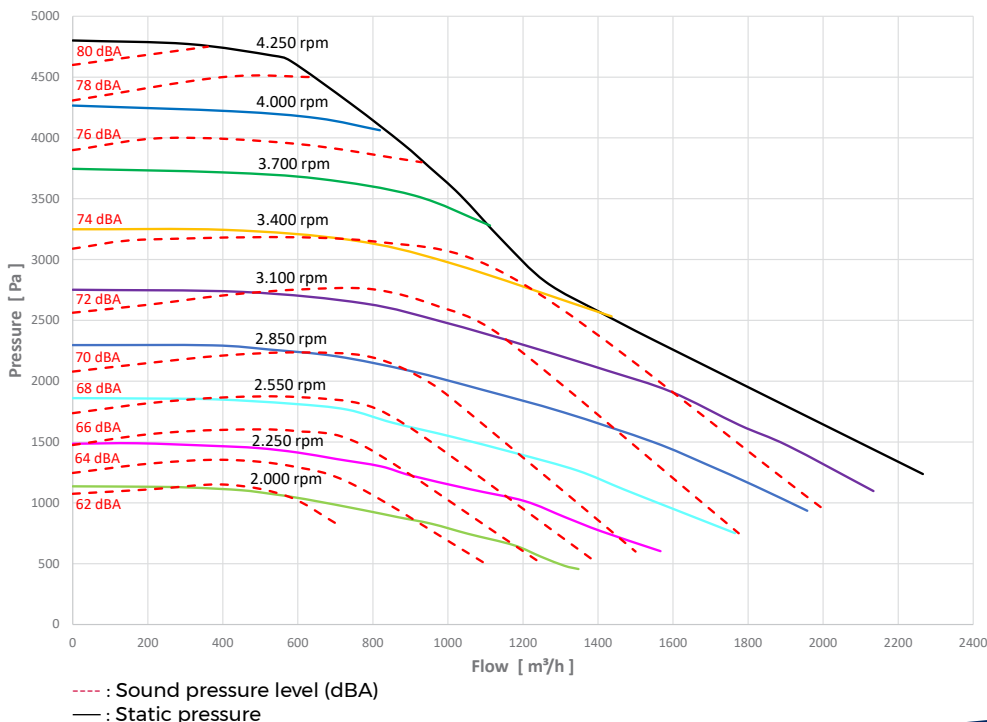

All values given are for Ø160 material pipe.

**Kongskilde Industries A/S**

Tel. +45 72 17 60 50

industry@kongskilde-industries.com

www.kongskilde-industries.com

