

Blowers

Data sheet

Kongskilde's FRL, FEA and TRL blowers constitute a range of proven conveying blowers, which are an ideal energy source for a vast number of industrial material handling systems.

The Kongskilde blowers are very suitable for a wide range of applications, including air supply, conveying purposes, and ventilation where high pressure are required.

The blowers can be used for both suction and blowing systems as well as suction-blowing-systems. They are not intended for corrosive gases and the air temperature must not exceed 70°C.

Description

The aerodynamic shape of the Kongskilde blower ensures high efficiency and low energy consumption.

The blowers are designed as centrifugal blowers with a perfectly balanced rotor, resulting in vibration-free operation and minimised noise levels.



Application

FRL/FEA

Kongskilde's FEA 10 is a one-stage centrifugal blower with a closed rotor with 6 forward curved blades. It is particularly suitable for ventilation tasks. Ideal applications include suction of welding fume and gases.

FRL 10 is a one-stage centrifugal blower with an open rotor and 8 backward curved blades. This allows light material, e.g. plastic flakes, to be successfully be conveyed through the fan. The blower is also very suitable for extracting light dust and shavings, and exhaust purposes.

Both types (FRL/FEA) are available with or without motor.

TRL

The Kongskilde high-pressure blowers are available in a wide range of sizes – offering a variety of performance characteristics capable to meet specific industrial requirements.

The TRL range with accessories is ideal for conveying of granular materials and similar products with specific weights between 0.2 and 0.8 ton/m³.

They are also very suitable for most suction purposes, e.g. suction of welding fumes, as well as many ventilation applications.

The small and medium-sized blowers are one-stage centrifugal blowers with closed rotors, whereas TRL 300 and 500 have two respectively three stages, which are also equipped with closed rotors.

TRL 55/100/150/200/300/500 are equipped with an air regulator. Combining the blower with an air regulator optimises the conveying air speed by keeping the air velocity below 25 m/s, which minimises damage to the material even when conveying delicate materials. The constant air velocity also prevents motor overload and minimises power consumption.

TRL 20/40 can be used as either transport blower or suction blower, while the TRL 55/75/100/150/200/300/500 can be utilised for both suction and blowing and can be installed as a combination suction-blowing-system.

TRL 20/40/55/75

TRL 20/40/55/75 are directly driven, and the TRL 20/40/75 are supplied with air intake mesh guards.

TRL 55 is supplied with an automatic air regulator.

TRL 100/150/200

Within the TRL 100/150/200 blowers, pressure and air volume can always be adjusted to the application thanks to the possibility of adjusting the rpm of the rotor.

The blowers can be fitted with 7.5 to 15 kW motors, which have been adjusted to the rpm of the rotor.

The blowers are delivered with V-belt transmission.

TRL 300/500

The special advantage of the TRL 300/500 blowers is that they are capable of delivering exceptionally high pressure due to the two-respectively three-step construction as each stage of the blower increases the air pressure.

Standard Equipment

The Kongskilde blowers are as standard delivered with motor, protection IP 55, and closed rotor.

TRL 20/40/55/75/100 are as standard delivered with motor, protection IP 55, but they are also available without the motor.

TRL 150/200/300/500 are as standard delivered with motor, protection IP 55, and automatic starter. They are also available without motor.

Accessories

Kongskilde's product range includes an assortment of rotary valves, injectors, cyclones and a wide range of pipe components, suitable for combination with the blowers. Please refer to Kongskilde's data sheets for more information on the specific items.

The TRL blowers can be equipped with the illustrated inlets.

Options

All blowers are available with motors suitable for 60 Hz. Directly driven blowers are supplied with different rotor sizes to suit the 60 Hz rpm.

In- and outlet on the blowers can be connected to the Kongskilde OK-pipe system.

The TRL 75 is available in stainless steel.

Dimensions

FRL 10/FEA10

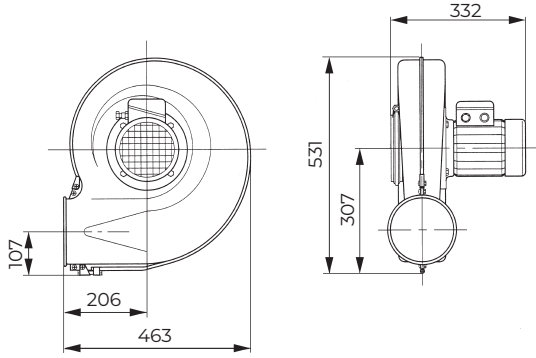

TRL 20

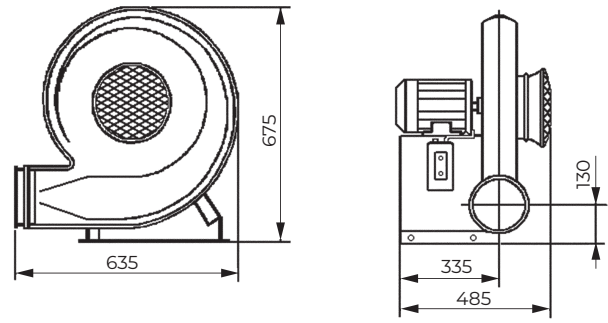

TRL 40

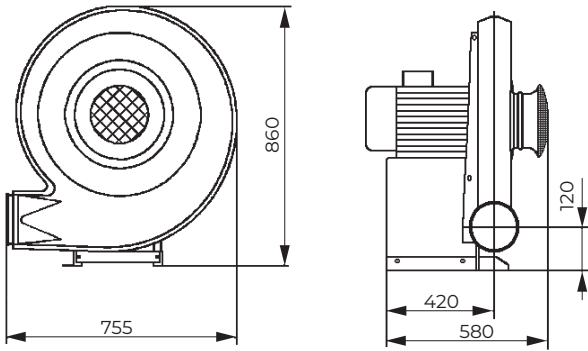

TRL 55

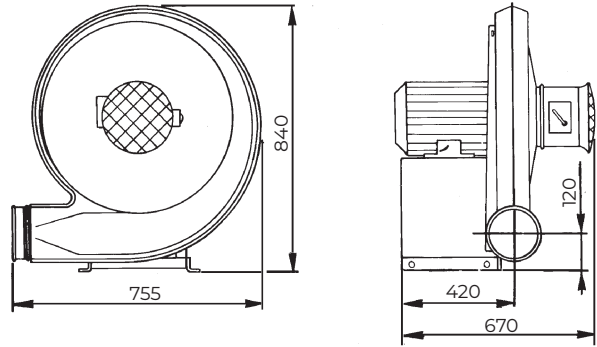

TRL 75

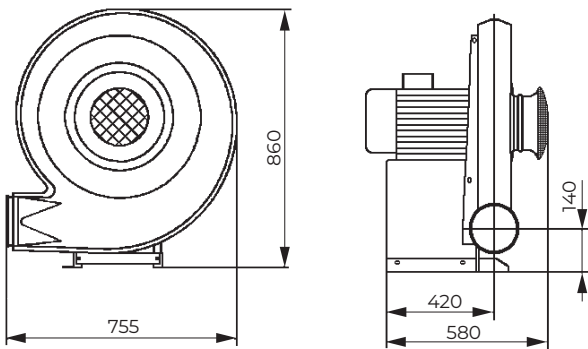

These drawings are based on our present technical knowledge. It is presented for information only and does not involve us in any commitment to supply.

Technical Data

	FRL 10	FEA 10	TRL 20	TRL 40	TRL 55	TRL 75
Motor rating, kW (Hp)	0.75 (1)	0.75 (1)	1.5 (2)	3 (4)	4 (5.5)	5.5 (7.5)
Motor rpm	2900	2900	2900	2900	2900	2900
Electrical supply, V/Hz	3 x 400 V, 50 Hz					
Amp. consumption	1.7	1.7	3.1	5.8	7.5	10.5
Min. fuse rating (approx.)	10	10	10	16	16	20
Rotor rpm	2900	2900	2900	2900	2900	2900
Weight w/o motor, kg	8.9	8.9	18	41	43	43
Weight w. motor, kg	21	21	35	67	76	96
Noise level, 1m distance dB (A)	76	76	83	82	91	85
Noise level, 7m distance dB (A)	61	61	64	64	77	71

Dimensions

TRL 100/150

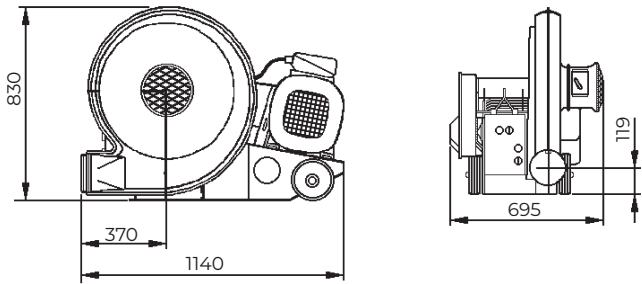

TRL 200

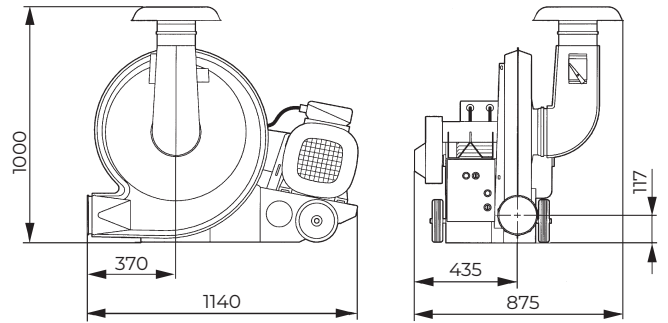

TRL 300

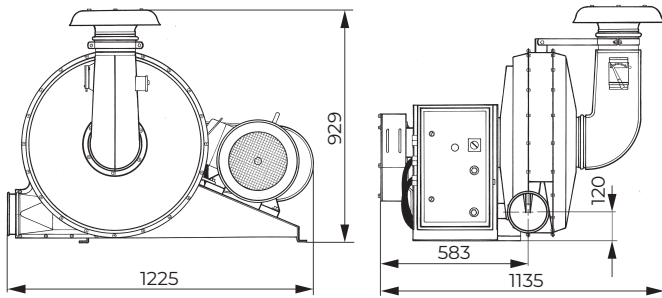

TRL 500

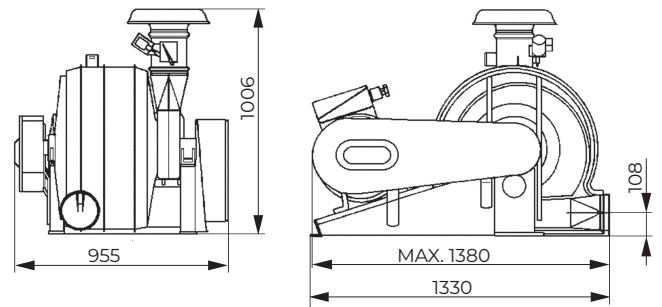

All blower outlets are OK160.

These drawings are based on our present technical knowledge. It is presented for information only and does not involve us in any commitment to supply.

Technical Data

	TRL 100	TRL 150	TRL 200	TRL 300	TRL 500
Motor rating, kW (Hp)	7.5 (10)	11 (15)	15 (20)	22 (30)	37 (50)
Motor rpm	2900	2900	2900	2900	2900
Electrical supply, V/Hz	3 x 400 V, 50 Hz				
Amp. consumption	13.5	20	27	39	65
Min. fuse rating (approx.)	25	35	50	63	100
Rotor rpm	3650	4200	4700	4100	4300
Weight w/o motor, kg	69	69	69	149	190
Weight w/ motor, kg	129	157	195	324	468
Noise level, 1m distance dB (A)	90	97		93	93
Noise level, 7m distance dB (A)	73	81		78	80
V-belt	SPZ 1787 3 pcs. ¹	SPZ 1787 3 pcs. ¹	SPZ 1787 3 pcs. ¹	SPA 1800 4 pcs. ¹	XPB 2000 3 pcs. ¹

¹ Please note that all V-belts must be re-ordered in matched sets.

Dimensions

TRL 600/750/1000

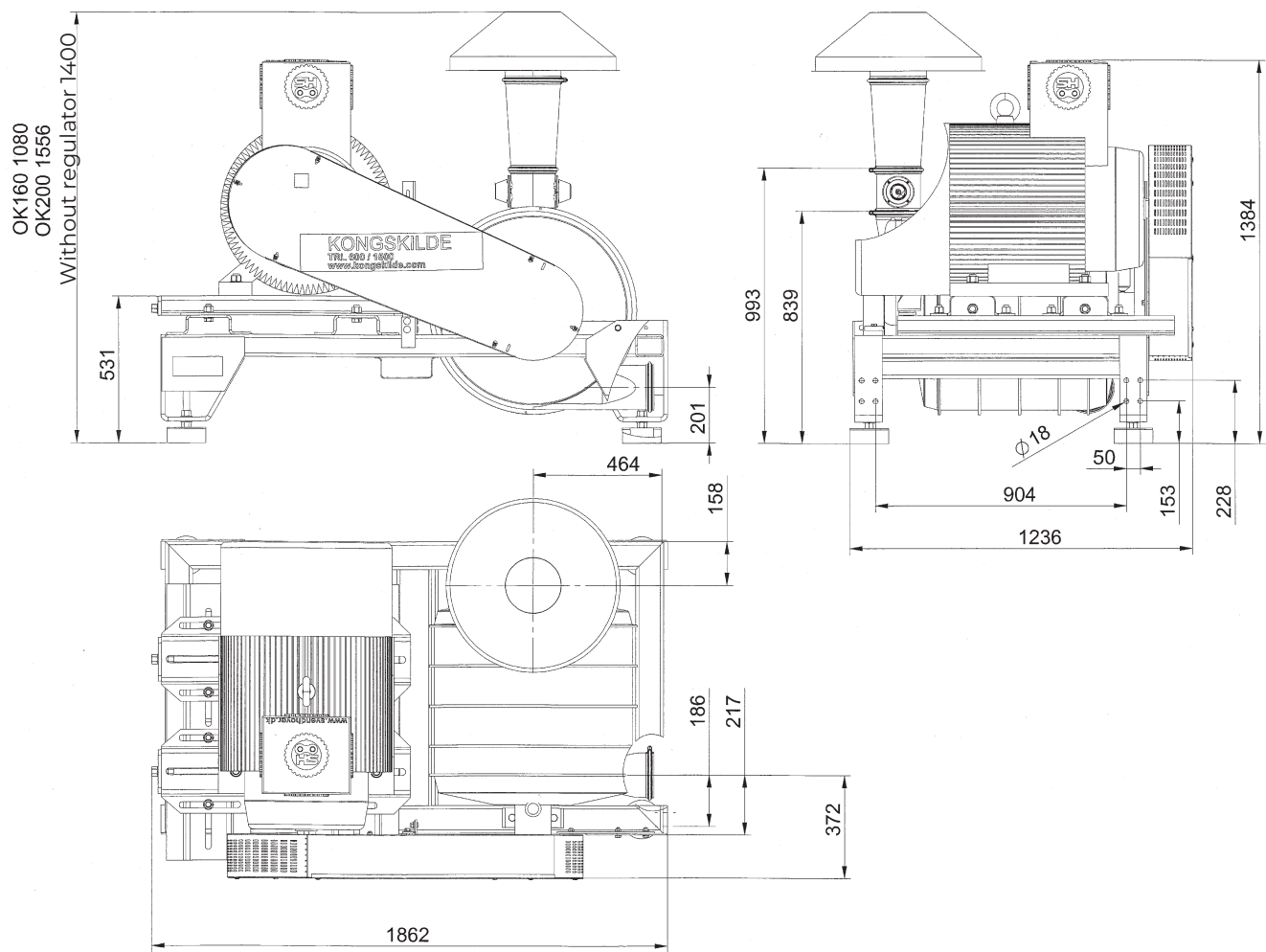

Technical Data

	TRL 600	TRL 750	TRL 1000
Motor rating, kW (Hp)	45 (60)	55 (75)	75 (100)
Motor current 400V, 50Hz	78	94	126
Motor rpm 50Hz/60Hz	2960/3550		
Amp.	78	96	129
Blower rpm with the OK160 throttle	3905	4310	4780
Blower rpm with the OK200 throttle	3375	3685	4280
Blower rpm without a throttle	3125	3440	3870
Weight w/o the motor (kg)	600	600	600
Weight w/ the motor (kg)	950	965	1065
Noise level, 1m distance dB (A)	95	95	95
V-belt	XPB 2500 3 pcs. ¹	XPB 2500 4 pcs. ¹	XPB 2500 4 pcs. ¹

¹ Please note that all V-belts must be re-ordered in matched sets.

Kongskilde's TRL blowers can be equipped with a number of inlets suitable for various applications. The possible inlets are illustrated below.

Inlets TRL 20/40/75

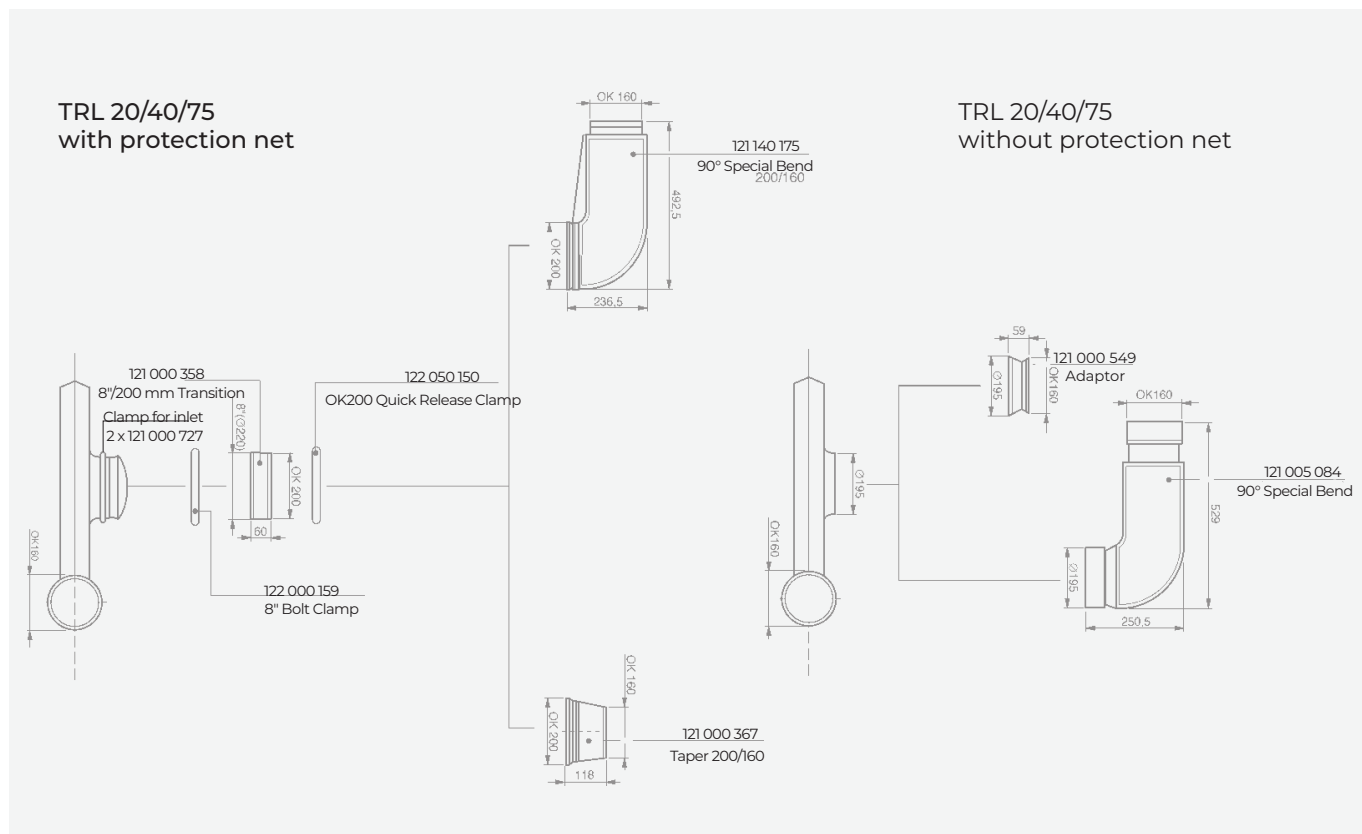

Inlets TRL 55/100/150

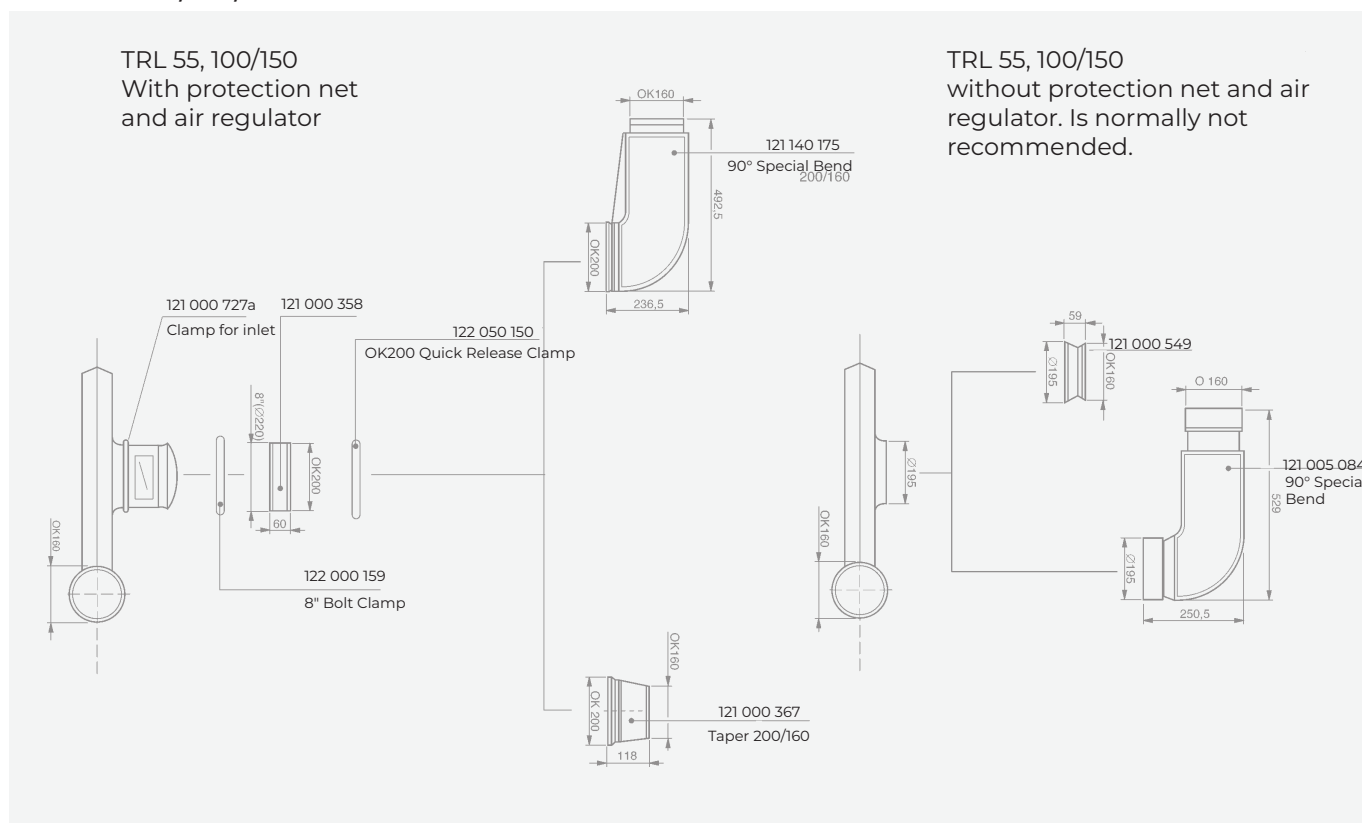

Pressure

FRL/FEA

Pressure total, P_t
kPa mm.WG.

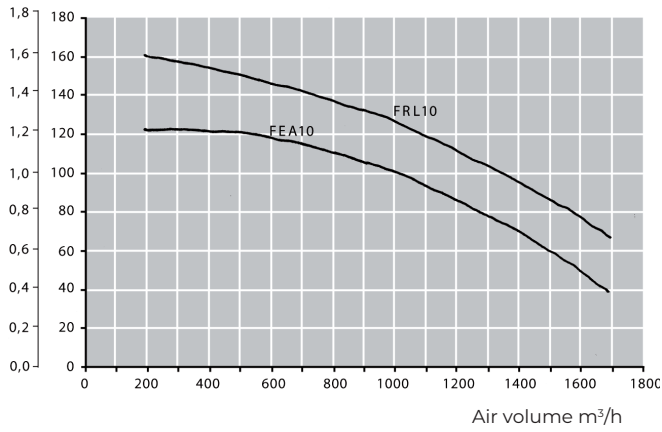

TRL

Pressure total, P_t
kPa mm.WG.

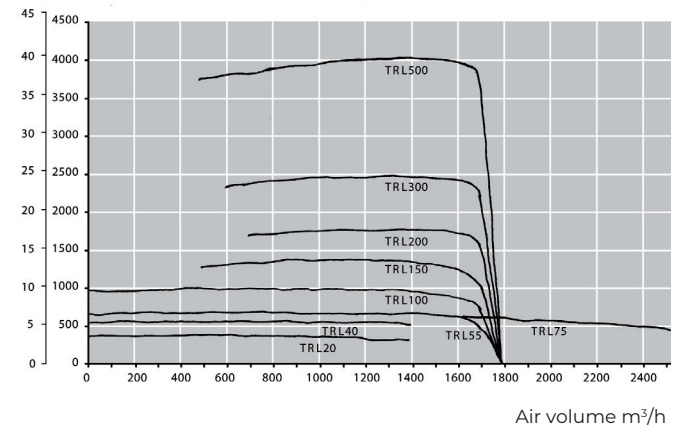

Performance curves for TRL600 – 1000 without air regulator:

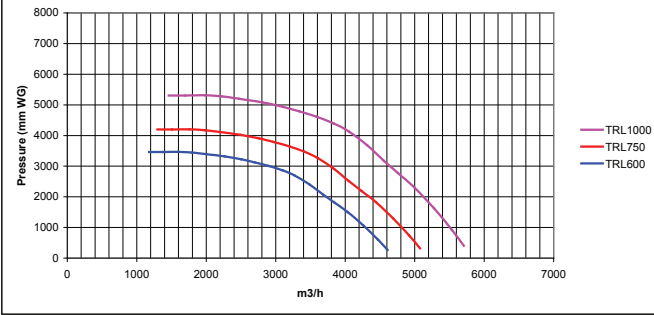

Performance curves for TRL600 – 1000 with air regulation for OK160:

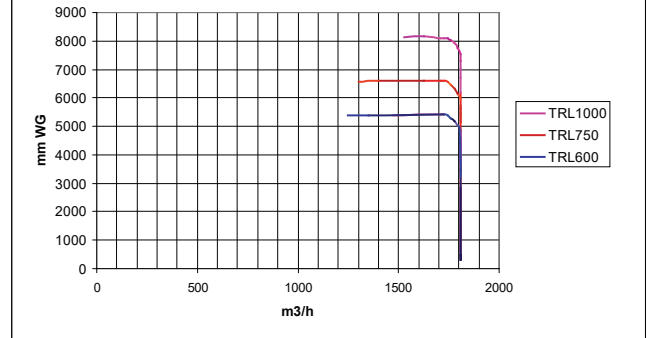

Air Volume

The max. air volume delivered by the TRL blowers with air regulator is approximately 1800 m³/h at different pressures depending on the type of blower. It is a general rule in pneumatic conveying that the higher pressure in the system, the higher the transfer rate.

Kongskilde Industries A/S

Tel.: +45 72 17 60 50

industry@kongskilde-industries.com

www.kongskilde-industries.com

