

# **KM 20 - 180**

## **Data sheet**

The Kongskilde KM 20 - 180 cyclones are designed for separation of dust and particles from air. Volumes from 1,000 to 35,000 m<sup>3</sup>/h can be handled by the KM range of cyclones.

The KM 20 - 180 cyclones is a fully welded construction and Kongskilde deliver the cyclones in a primed and painted (Space blue) finish.

Inlet, top outlet and bottom outlet is available in various sizes.

An accessory the cyclone can be delivered with standard legs for easy and solid mounting.



# Technical Data

Pressure

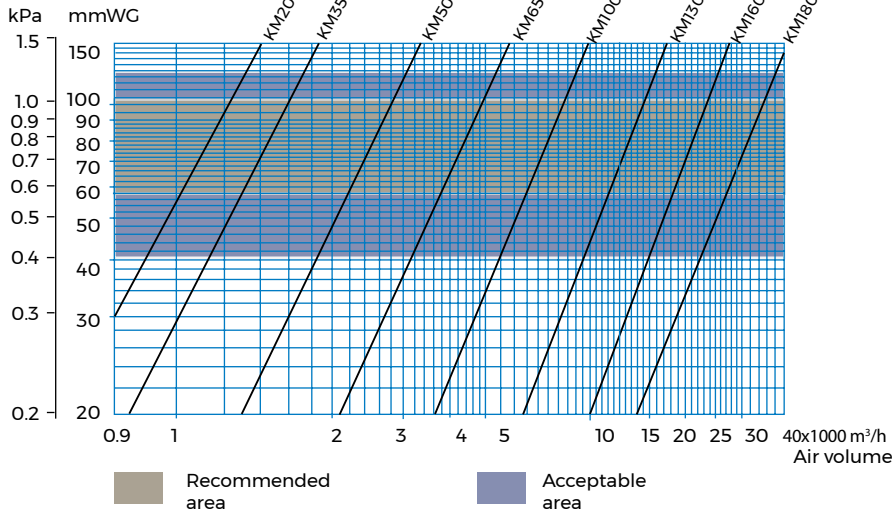

## Dimensions

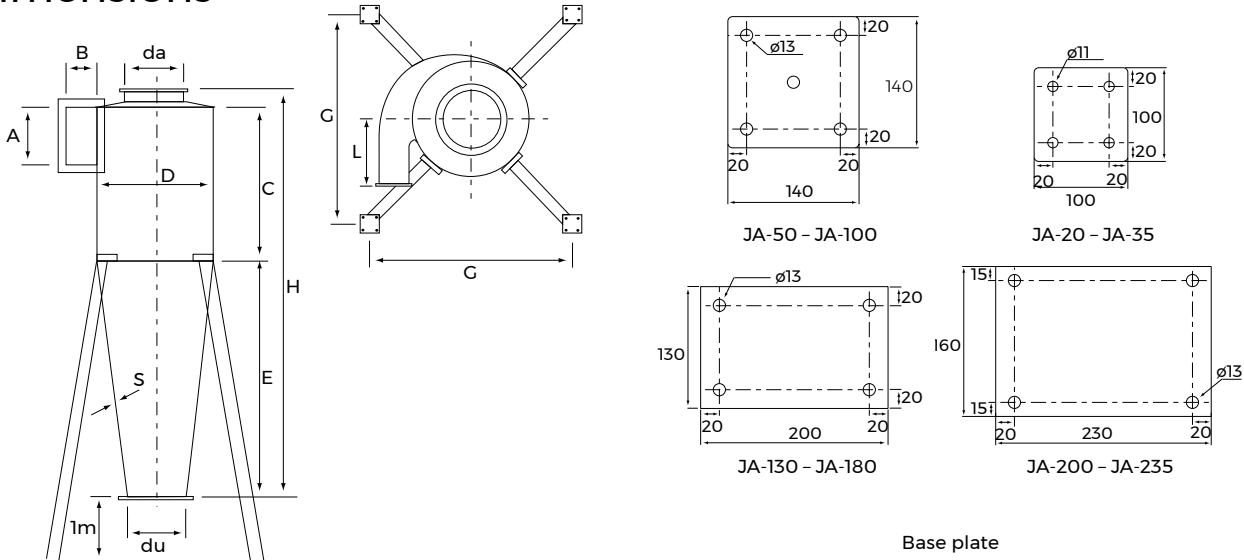

Type	A mm	B mm	C mm	D mm	da mm	du mm	E mm	G mm	H mm	S mm	K mm	L mm	Weight kg	Standard inlet/length, mm
KM20	230	100	570	400	225	160	820	1050	1465	2	234	240	49	FK140/242
KM35	285	125	710	500	250	200	1020	1200	1790	2	290	300	59	OK160/242
KM50	350	160	710	500	250	200	1020	1200	1790	2	308	300	70	OK200/242
KM65	445	200	995	700	400	300	1405	1530	2500	2	419	420	115	Ø300/392
KM100	560	300	1500	1000	550	400	2050	1960	3725	2	615	600	270	Ø400/392
KM130	750	400	2000	1280	700	450	2820	2305	5090	3	782	700	565	Ø600/492
KM160	1100	500	2000	1600	800	550	3150	2690	5420	3	1050	900	685	Ø700/592
KM180	1500	600	2500	1800	1000	650	3450	2790	6250	3	1150	950	875	Ø900/600

**Kongskilde Industries USA Inc.**  
 1802 Industrial Park Drive, Unit A  
 Normal, IL 61761  
 Tel.: (309) 452-3300  
 kna@kongskilde-industries.com  
 www.kongskilde-industries.com

