

MultiAir 3000

Data sheet

The MultiAir is used in connection with other Kongskilde equipment in order to convey products from the plastic, packaging and printing industries.

The Kongskilde range of high pressure MultiAir blowers is specifically designed as an integral part of the Kongskilde pneumatic conveying range of equipment. The MultiAir is used in connection with other Kongskilde equipment in order to convey products from the plastic, packaging and printing industries.

The MultiAir 3000 series are a new generation of high efficiency highpressure blowers, which are very reliable, save power, have a low noise level and low maintenance.

The MultiAir 3000 series are available in two sizes and two versions: MultiAir 3300 and MultiAir 3500 both available as S and T versions.

The S version can be used as a vacuum blower or a combined vacuum and pressure blower.

The T version can only function as a pressure blower.

Both MultiAir 3000 sizes are mounted with either IEC or UL approved electrical equipment.

Tests carried out so far have proven that the noise level is considerably lower than a traditional blower. When the MultiAir 3000 is running at 100% load, the noise level is in the range of 70 dBA. This low noise level is due to a new built-in insulation, which is mounted inside the blower housing, as well as a new design of the blower outlet.

Technically the MultiAir 3000 series are dual rotor blowers, which can give up to 2950 CFM of air and have 134" WG as the highest pressure available.

The MultiAir 3000 series can as previously mentioned be delivered in 2 versions. The MultiAir 3300 has a power consumption up to 30 HP at the maximum load, and the MultiAir 3500 has a power consumption up to 50 HP.



Principle

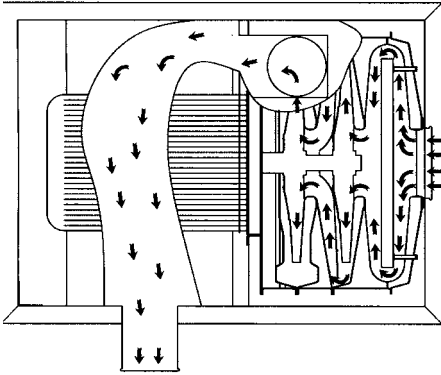

MultiAir type	3300	3500
Max. output power (HP)	30	50
Max. power consumption (A)	39	65
Motor speed (rpm)	0 - 4800	0 - 4800
Weight T-model (lbs)	1485	1485
Weight S-model (lbs)	1452	1452
Noise level (dB(A))	approx. 70	approx. 70

Function

The new blower is designed to work with a high performance when required and an automatic power saving when the maximum performance is not required. Traditionally systems run at full capacity when started even though the requirements and load of the system vary. As something new, the MultiAir 3000 series have the possibility to automatically adjust the performance due to the requirements of the main machinery or production machines.

Optional for the MultiAir 3000 series is also remote control panels. These remote control panels make it possible for the end user to regulate and/or survey the MultiAir 3000 from several locations.

The MultiAir 3000 may be delivered with remote control panels (max. 2 panels per MultiAir 3000). The distance from the main panel to the farthest remote control box can be up to 18,000 feet.

The blower is equipped with an inverter, which controls the performance. This inverter goes up to 87 Hz for both models and because the blower is directly driven, this gives a rotor speed at maximum ~ 4800 rpm.

This gives the user an easy way to adjust the performance of the blower to the exact requirements of the main machinery thus minimizing the power consumption.

Capacity

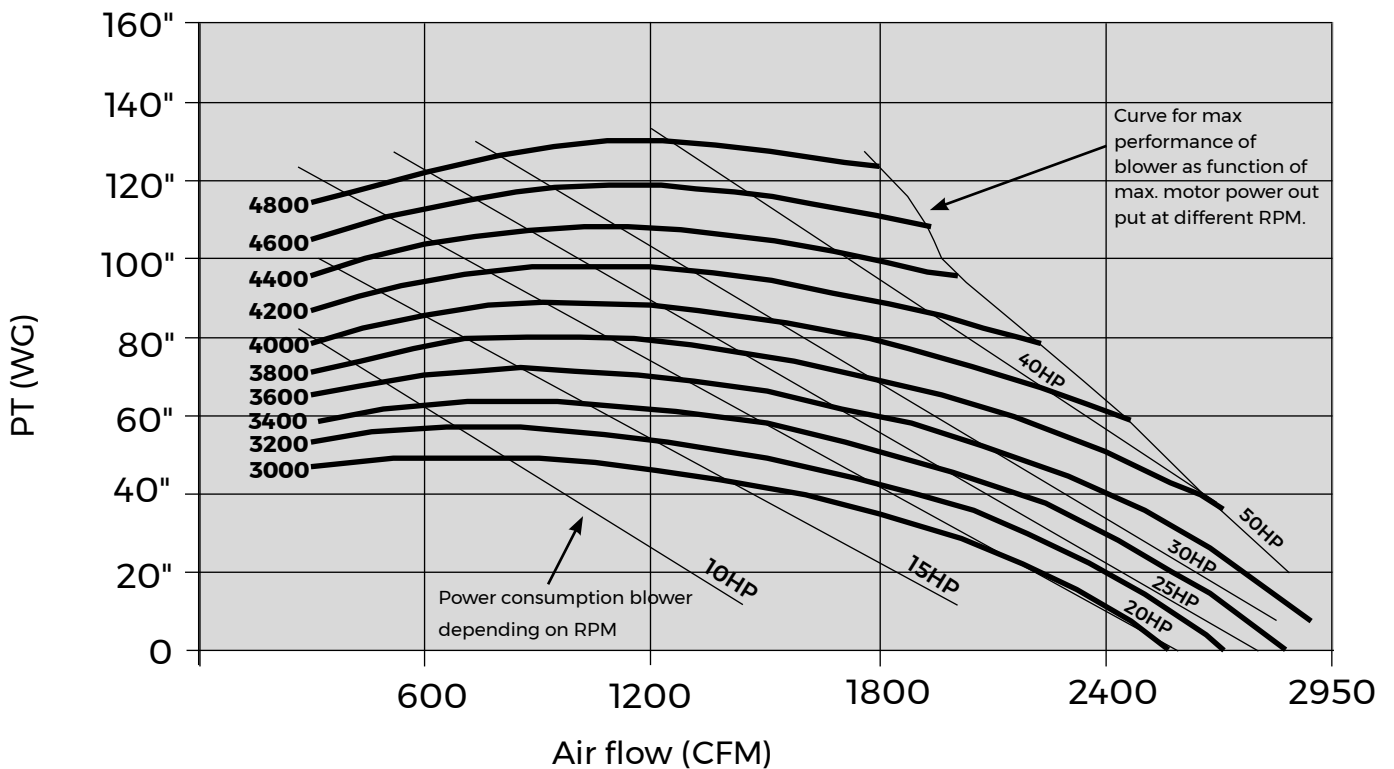

Standard

The MultiAir 3000 series can easily be adjusted on the inverter to match the exact requirements just by using a touch screen. Often the production machinery can give a signal to the inverter, which enables the inverter to adjust the performance of the blower to the current system requirement.

A system design leads to a certain required power for waste case scenarios. When the system has been installed, it might have to be regulated down to match the normal conditions and requirements. The traditional way of adjusting a system is to have a throttle valve or slide gate to increase the backpressure in the system, thus decreasing the flow in the system. The blower would still run at 100% and almost use the maximum power.

Optional

Depending on the system requirements, the MultiAir 3000 series are available with two additional control options; a pressure control system or a flow control system. The control systems make it possible for the MultiAir 3000 to adjust the performance automatically to the actual load of the system, thus minimizing the power consumption.

MultiAir panel with built-in inverter

As standard the panel includes 2 motor starters for external motors on additional equipment; ex. MultiCutter and Separator.

Two modules always have to be installed to make the panel working.

One of each is standard in the panel.

1 - 3 HP (1,25A - 5,0A)

3 - 5 HP (3,0A - 12,0A)



Dimensions

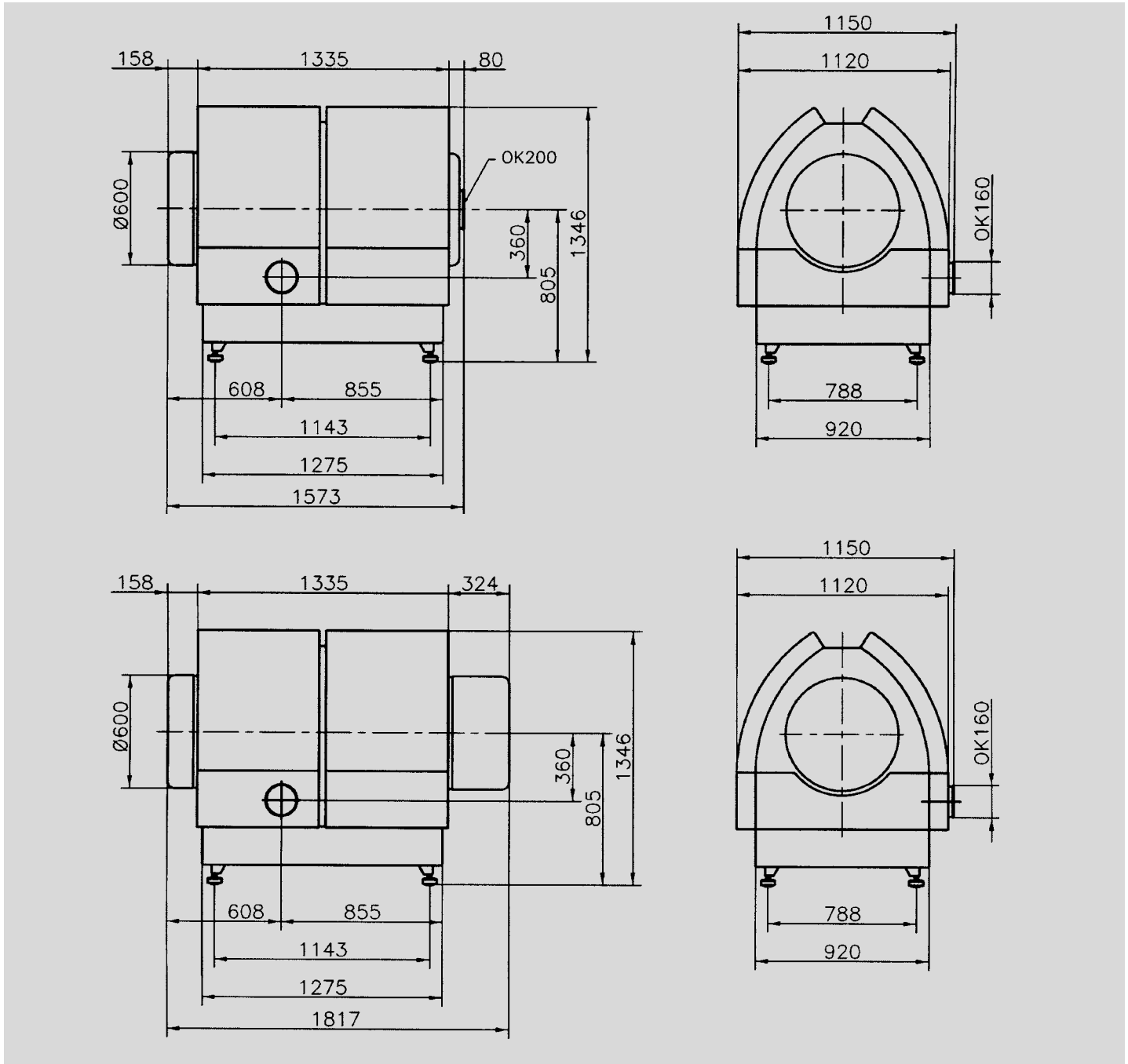

Subject to be changed without notice. 123001617 KNA/GB/MultiAir 3000/DATA/0618

Kongskilde Industries USA Inc.
1802 Industrial Park Drive, Unit A
Normal, IL 61761
Tel.: (309) 452-3300
kna@kongskilde-industries.com
www.kongskilde-industries.com

