

Short Introduction for the Correct Installation and Use of Kongskilde OK-Pneumatic Conveying Pipe System for Industrial use.

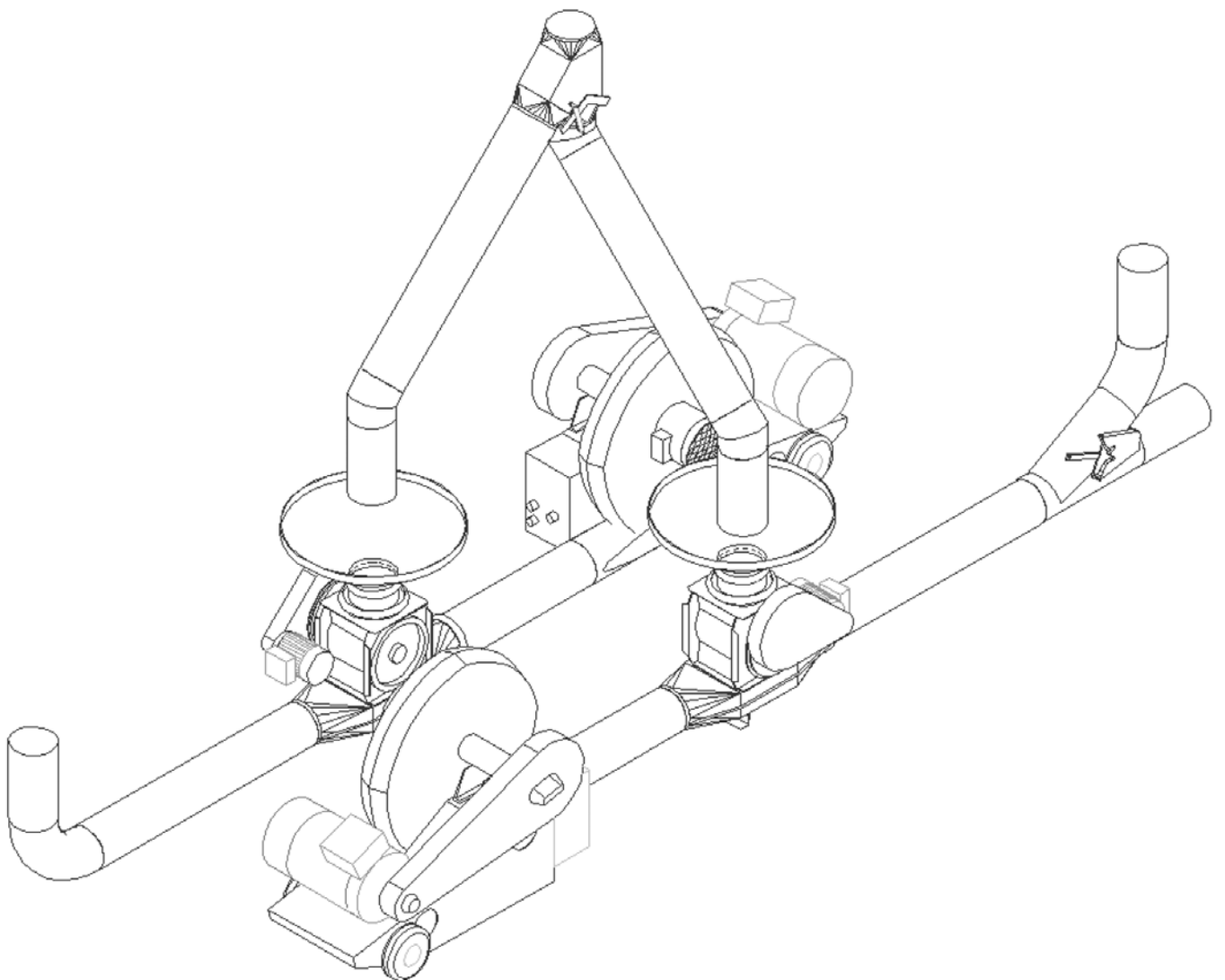

Content	Page
1.0 BLOWER.....	3
1.1 INSTALLATION OF MULTIAIR BLOWER.....	3
2.0 ROTARY VALVES.....	4
2.1 INSTALLATION OF ROTARY VALVES.....	4
2.2 SEVERAL ROTARY VALVES ON ONE PIPE LINE.....	5
3.0 GENERAL PRINCIPLES FOR INSTALLATION AND USE OF PIPES AND BENDS.....	6
3.1 DISTANCE BETWEEN BENDS.....	6
3.2 INSTALLATION OF TELESCOPES.....	6
3.3 INSTALLATION OF BENDS.....	6
3.4 DIVERTERS.....	7
3.5 BLOWING DIRECTION.....	7
3.6 FLEXIBLE PIPING.....	7
3.7 SUPPORTS.....	7
3.8 CONNECTIONS AND CENTERING.....	8
3.9 CYCLONES.....	8
3.10 OKD DOWNPIPE MATERIAL.....	9
4.0 PIPE LAYOUT.....	10
4.1 DIRECTION OF PIPELINE.....	10
4.2 CONVEYING TO TWO OR SEVERAL DIFFICULT ACCESSIBLE DESTINATIONS....	10
4.3 FLEXIBLE SUCTION PIPE.....	11
4.4 CONDENSED WATER IN OUTDOOR PIPING SYSTEMS.....	11

1.0 Blower

1.1 Installation of Multiair blower.

Be certain that the motor runs in the correct direction, so that the rotor follows the direction indicated with arrow on the blower housing.

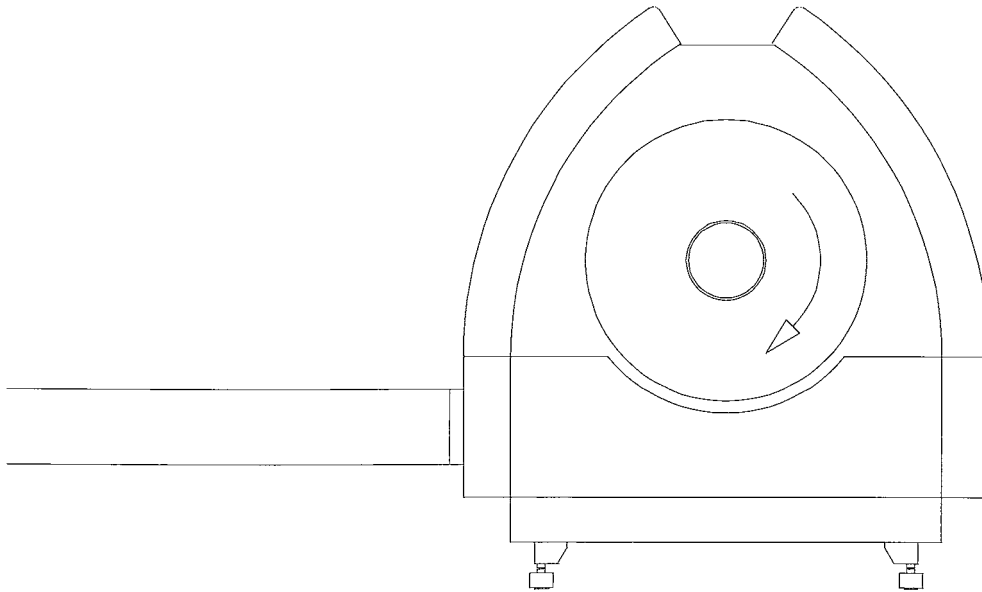

If the motor runs in the wrong direction, the direction can be changed by changing two electric phases. Any phases can be changed, but the earth conductor must not be moved.

NOTE: Shall only be carried out by authorised staff.

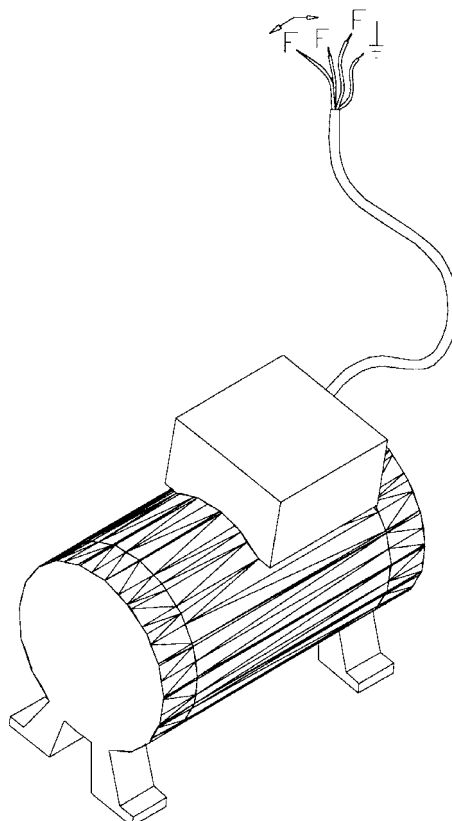

2.0 Rotary valves

2.1 Installation of rotary valves.

Check that the rotary valve is placed in the right way. A small air flap is mounted in the air supply side. The air flap directs the airflow downwards and away from the rotor, so that the material will easily fall down into the airstream. If the rotary valve is placed in the opposite direction, the material will not fall down into the airstream.

Also ensure that the rotor runs in the correct direction. The rotor shall rotate so that the granulate falls into the air entry side of the rotary valve. If the rotary valve is seen as illustrated below, the rotor shall run counter clockwise. If it does not run in this direction, the rotary direction can be changed by changing the electric supply phases (see chapter 1.1 about the blower).

It is recommended to install a wide open hopper above the rotary valve inlet. The inlet of the rotary valve shall be considerably larger than the feeding spout. An overpressure of air in the chambers of the rotary valve is constantly built-up in the chambers returning from the pressure side. This air shall slip away, which is not possible when the feeding spout is clamped directly on to the rotary valve inlet. The consequence hereof will often be inferior filling of the chambers and plugging of the pipes above the rotary valve.

To avoid irregular feeding, which e.g. might be the case after a dump weigher a shutter can be mounted right above the rotary valve. The shutter is adjusted to obtain an even and constant flow of material to the rotary valve.

The rotary valve will normally have a higher capacity than the blower, - the input capacity of material must be adjusted with a shutter.

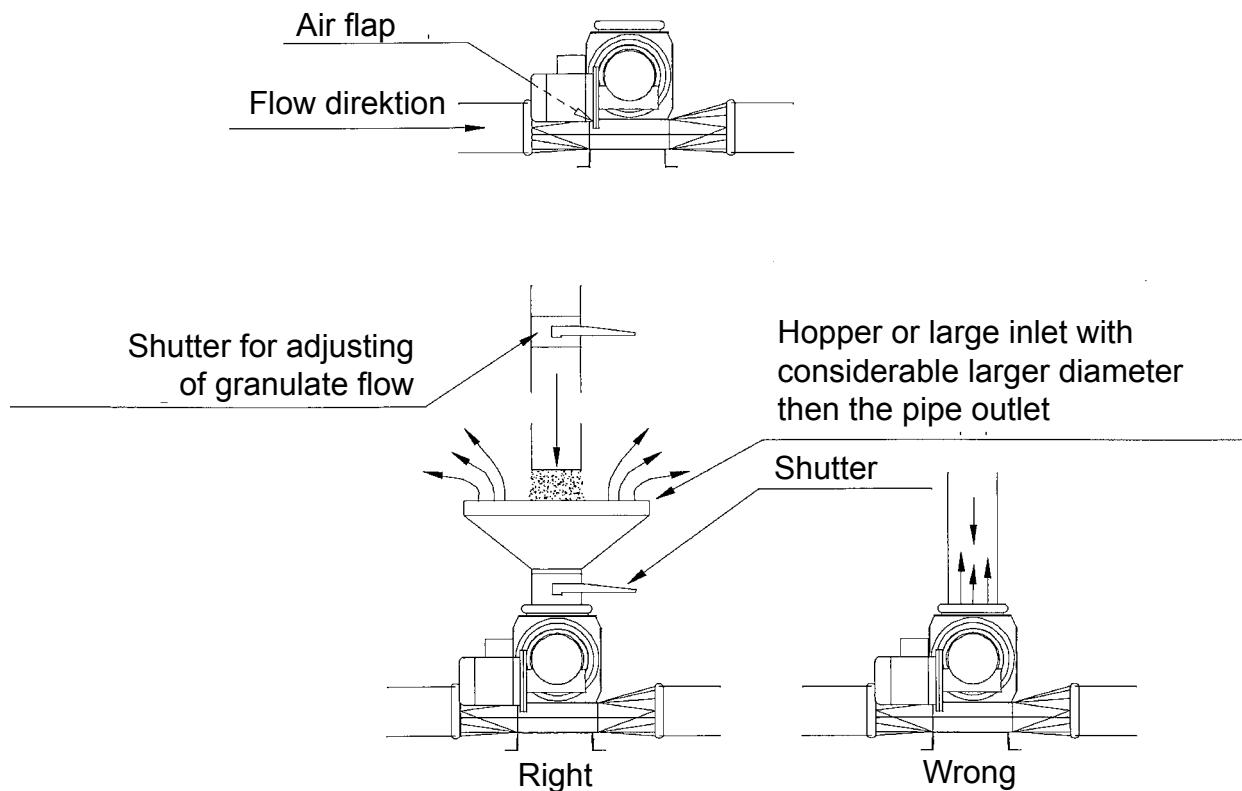

NOTE: If the rotary valve is dismantled, make sure that it is assembled correctly again! - The top part/rotary valve and bottom part/outlet can be assembled inversely!

2.2 Several rotary valves on one pipe line.

Airflow passing a rotary valve in a pipe line does not reduce capacity. Passing material through many rotary valves in the same pipe line reduce capacity considerably.

Therefore max. 3 rotary valves in line are recommended. With more than 3 rotary valves, a "by pass" can be made.

Wrong

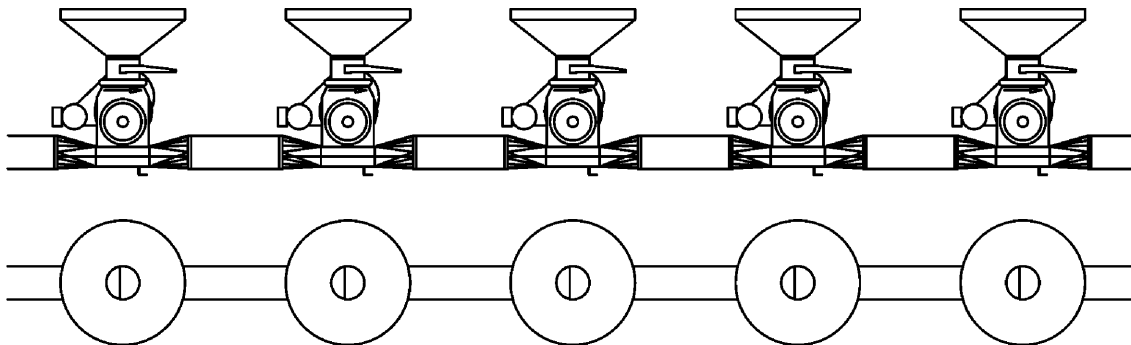

Right

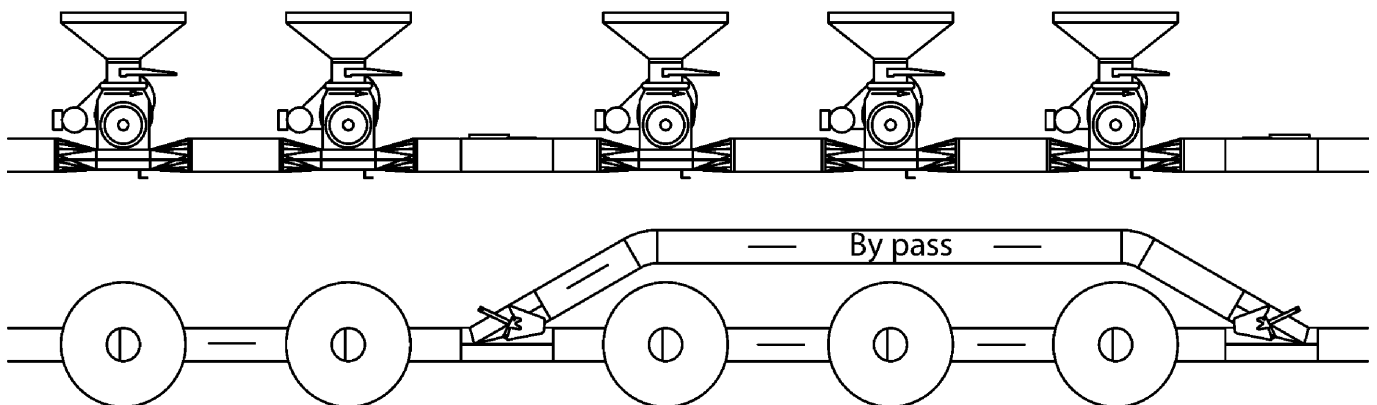

3.0 General principles for installation and use of pipes and bends

3.1 Distance between bends.

There should be a minimum distance of 2M between any flow direction change, i.e. between any bends. With larger TRL blowers moving higher capacities, longer distances are even better. This does not apply if only air is blown through the system.

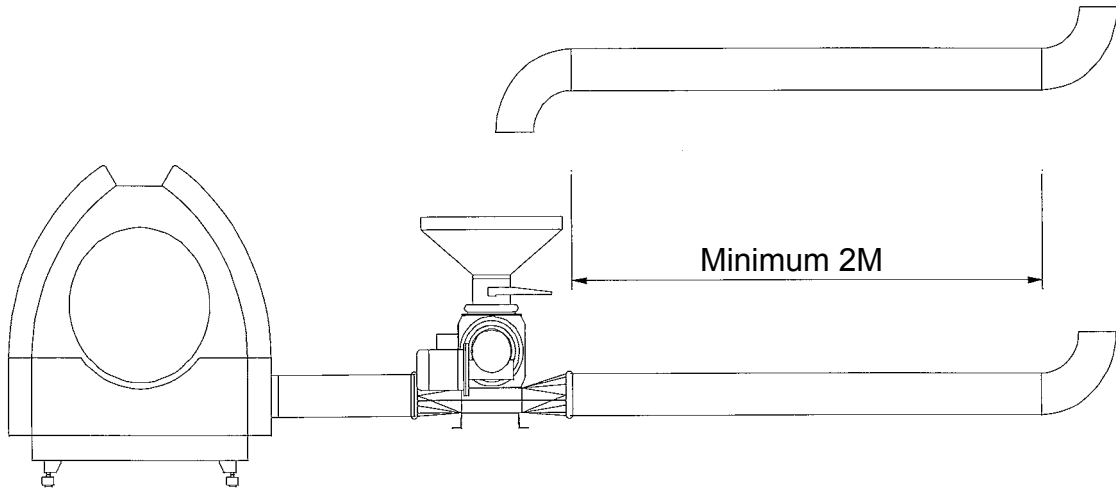

3.2 Installation of telescopes.

Always ensure that telescopes are installed so that the sharp edge points in the flow direction – not against. If telescopes are installed in the wrong way, damage to the material may occur. When conveying e.g. paper waste, a reverse telescope will create plugging problems.

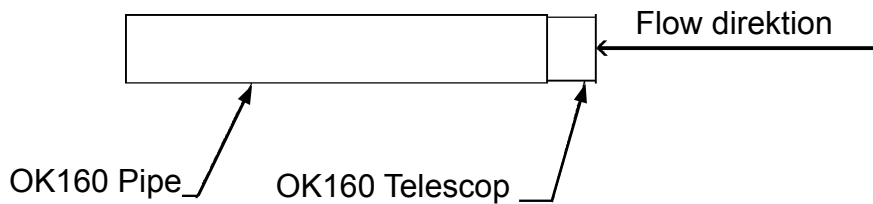

3.3 Installation of bends.

Do not put 2 bends back to back, as this will cause damage to the material and there will be a loss of capacity. It is recommended to use a heavier 1M pipe (OKR/OKD) following each bend to compensate for wear.

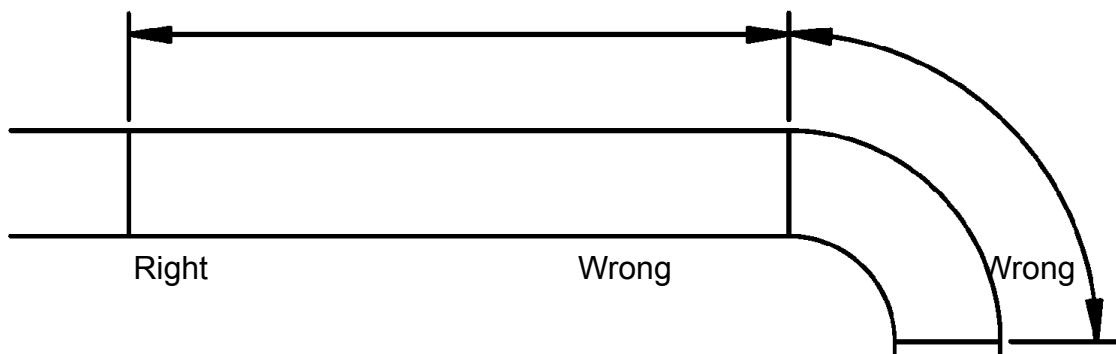

3.4 Diverters.

When using diverters, the same applies as mentioned above for bends, however, if space is narrow, 1 meter between a bend and a diverter is recommended. If necessary, the installation of a bend following the diverter in the outlet direction is acceptable, which will create a considerably faster wear of the bend. Do not blow material directly from a bend into the diverter, which will create a fast wear of the diverter.

It is possible to blow in each direction and suck through an OK160 diverter, type 122 000 690.

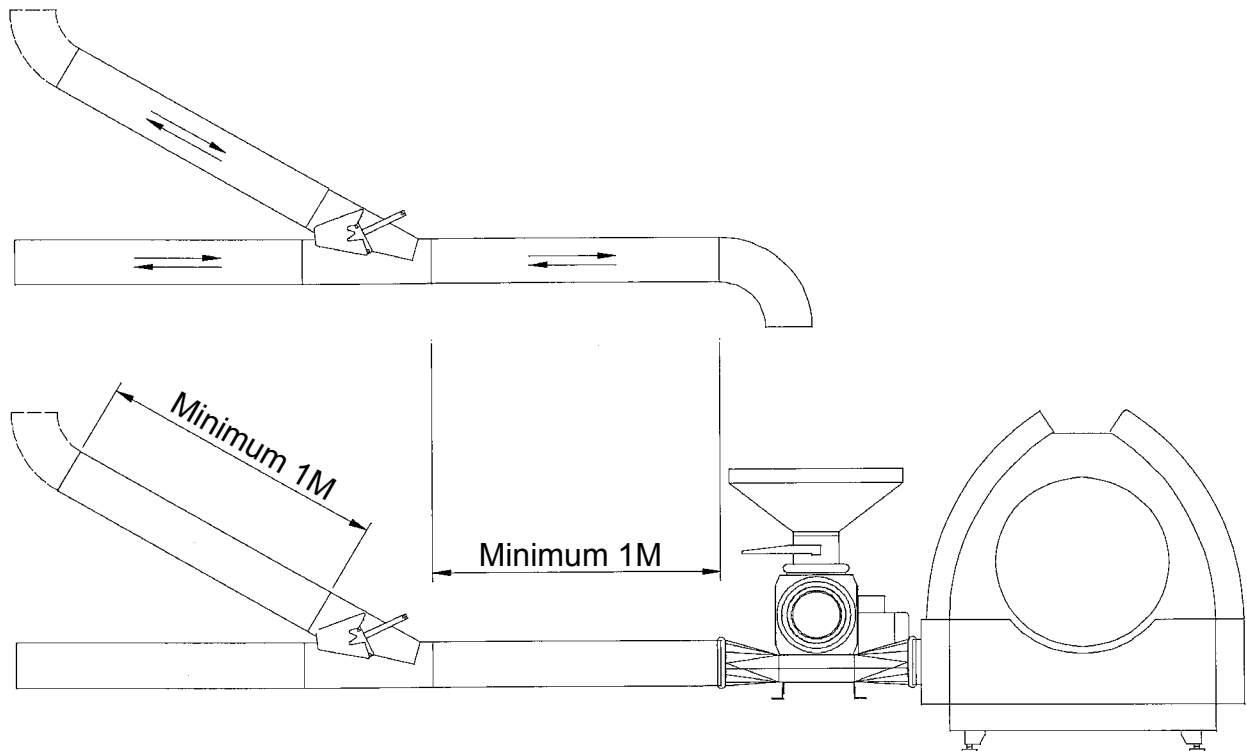

3.5 Blowing direction

Do not attempt to blow grain downwards, where gravity will add to the conveying speed. Damage to the grain and pipes (bends) will occur due to the high speed.

3.6 Flexible piping

Do not attempt to blow through flexible down pipe sections. Damage to the granulate and to the flexible pipe may occur.

3.7 Supports

The pipe line shall either be supported or suspended at a distance of max. 4 metres. Furthermore, it is recommended to support the pipe as close to the bends as possible.

3.8 Connections and centering

When connecting the pipes, bends and other material, which are designed for high speed conveying, it is important to center the pipes as precisely as possible at the connecting points.

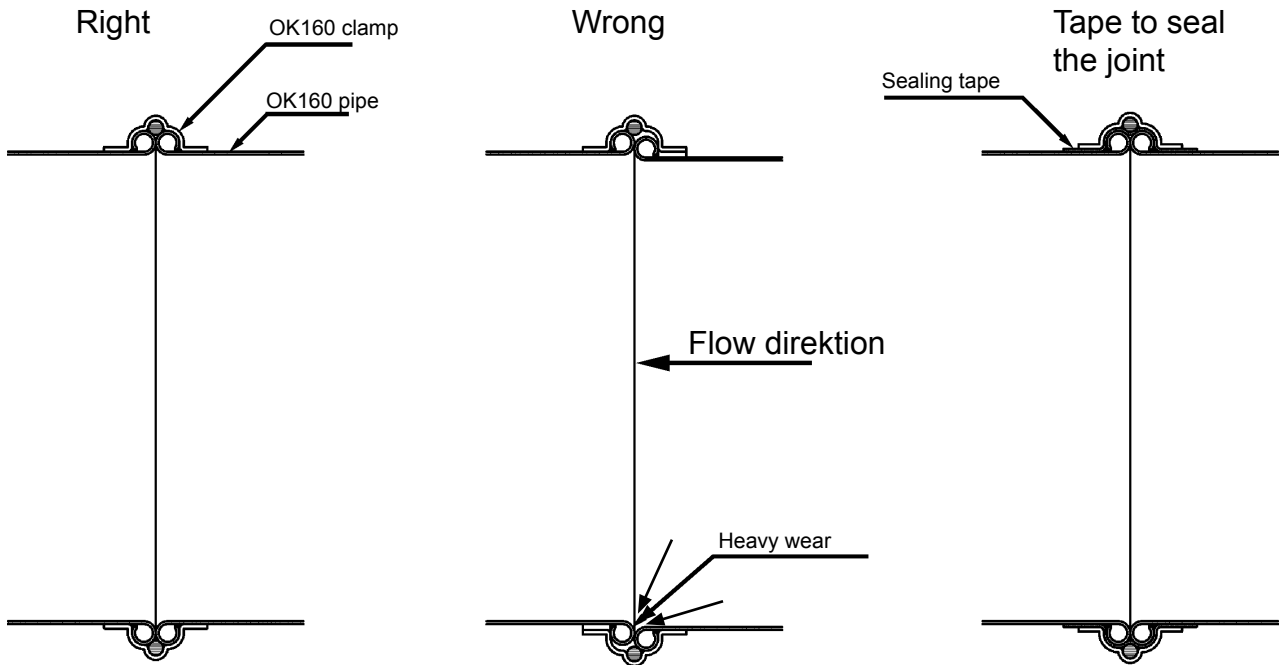

Do not rely on centering the pipe with the clamps alone. The clamp is designed for pressing the OK-pipe ends very hard together in order to ensure a very high tightness. This causes the friction between the pipes to become so high, that the clamp is unable to center the pipes. Check gap between clamp and pipe to ensure it is similar on both sides. Check the pipeline visually to secure a straight line.

If the pipes are not centered, the wear on the connection result in a fast wear out.

If a completely tight connection is required, the connection can be winded with sealing tape before installing the clamp.

3.9 Cyclones

When installing a cyclone in the pipe system, it is important to obtain the right entry angle.

Do not install a bend turning in the opposite direction of the cyclone right in front of the entry. If this is done, the effect of the cyclone is more or less neutralized.

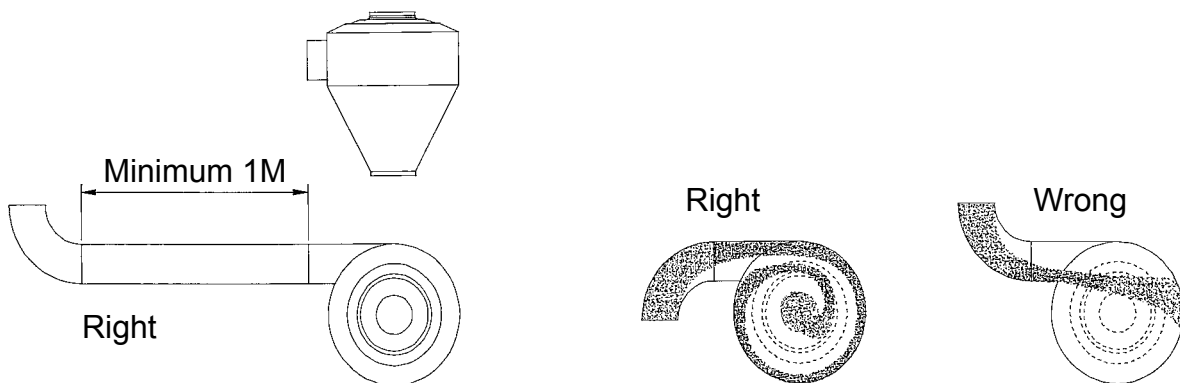

If it is necessary to install a bend prior to the cyclone, it shall bend in the same direction as the cyclone, or a straight pipe of minimum 1 meter must be installed between them.

3.10 OKD downpipe material

Do not use OKD downpipe bends and diverters in a pneumatic conveying system. Down pipe components are not airtight, resulting in loss of capacity and damage to the material.

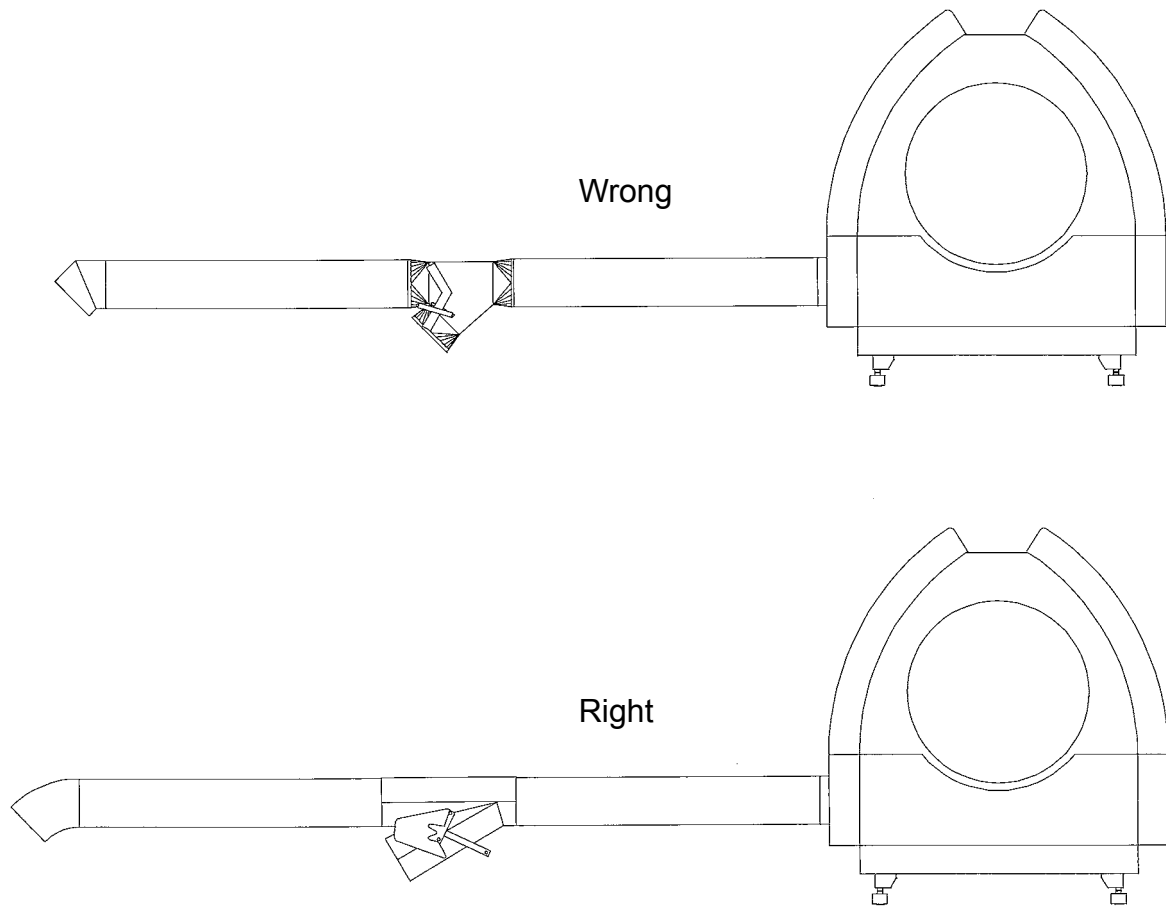

4.0 Pipe layout

4.1 Direction of pipeline

Keep the pipeline horizontal or vertical. Longer sloped rising or falling distances will result in wear on the pipes, risk of plugging of pipes, damage to the grain and capacity loss. The only time sloping pipe layout is advisable is right before the granulate reaches its destination.

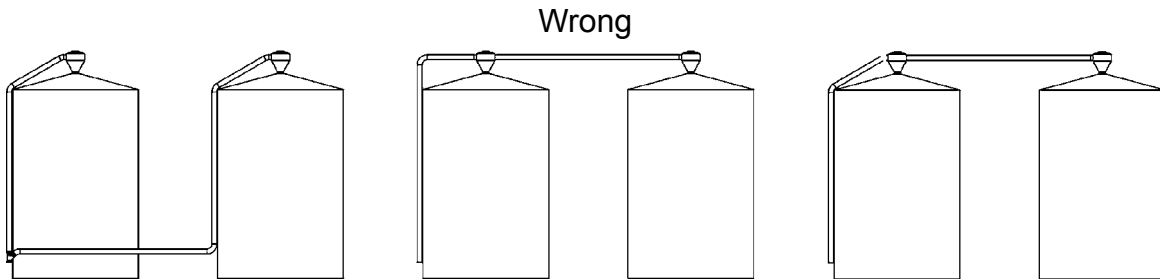

Ex. 1

Right

Ex. 2

4.2 Conveying to two or several difficult accessible destinations

When conveying grain through areas, where service is difficult, e.g. high silos, it can be considerably less expensive long term to use several separate pipelines, as in example 1. Investment is slightly more expensive than example 2, but it is normally easier and less expensive to make service on this plant, and wear on the pipes is reduced considerably, because not all granulate for both silos should pass through the same pipe.

The most simple and less expensive solution for conveying to several silos, will often be a system of loose pipes in floor height, which with OK-quick release clamps easily can be connected to one or the other silo.

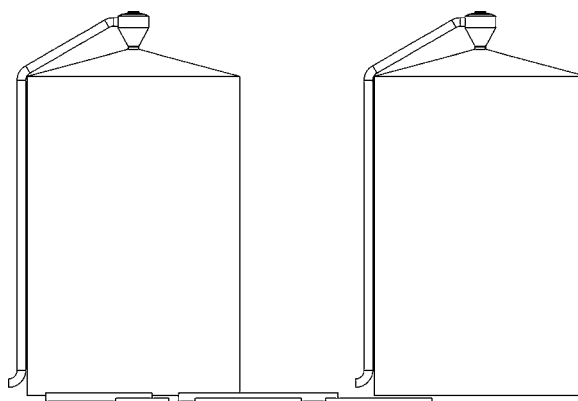

4.3 Flexible suction pipe.

When emptying silos and on-floor storage plants with suction equipment, do avoid bending the flexible pipe in a sharp curve. The sharper the pipe is bended, the harder the wear will be and the lower the capacity obtained. It is not necessary to install the flexible pipe right after the suction head.

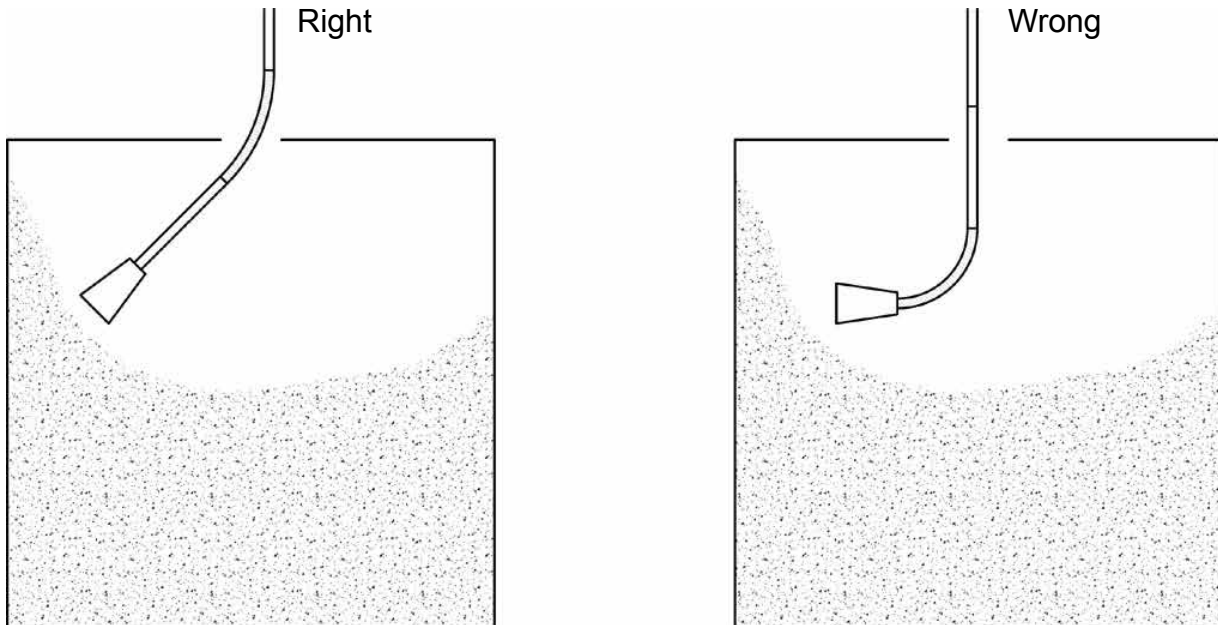

4.4 Condensed water in outdoor piping systems.

With outdoor piping systems condensed water will arise in the pipes especially in the winter time. Therefore it is recommended to disconnect a pipe or a bend at the lowest points, when the system is not to be used for a longer time in order to avoid water accumulation and rust.

If diverters are installed outdoor, these should stay in the middle position so that water can not be accumulated here thus reducing rust and corrosion.

If possible blower, rotary valve and diverters shall always be placed indoor/ under roof.

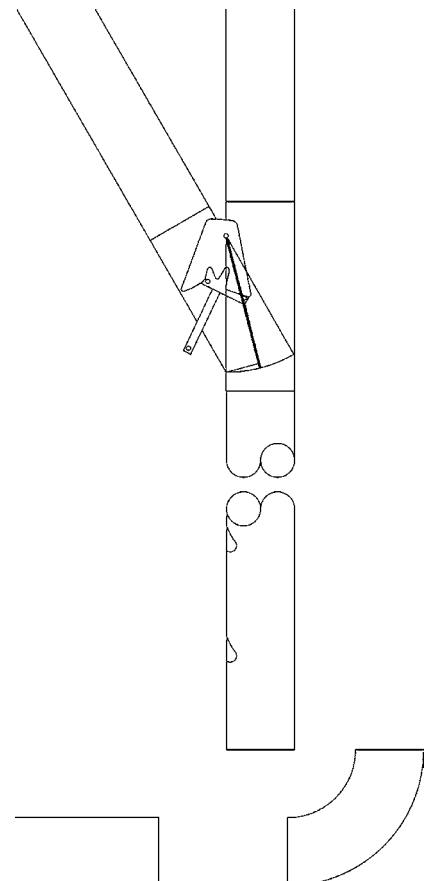

Kongskilde Industries A/S

Skælskørvej 64

DK - 4180 Sorø

Tel. +45 72 17 60 00

mail@kongskilde-industries.com

www.kongskilde-industries.com

www.kongskilde-grain.com



Air solutions / your success