

# KBE 60/80 Bucket Elevator – Spare Parts list.

Bucket elevator head.

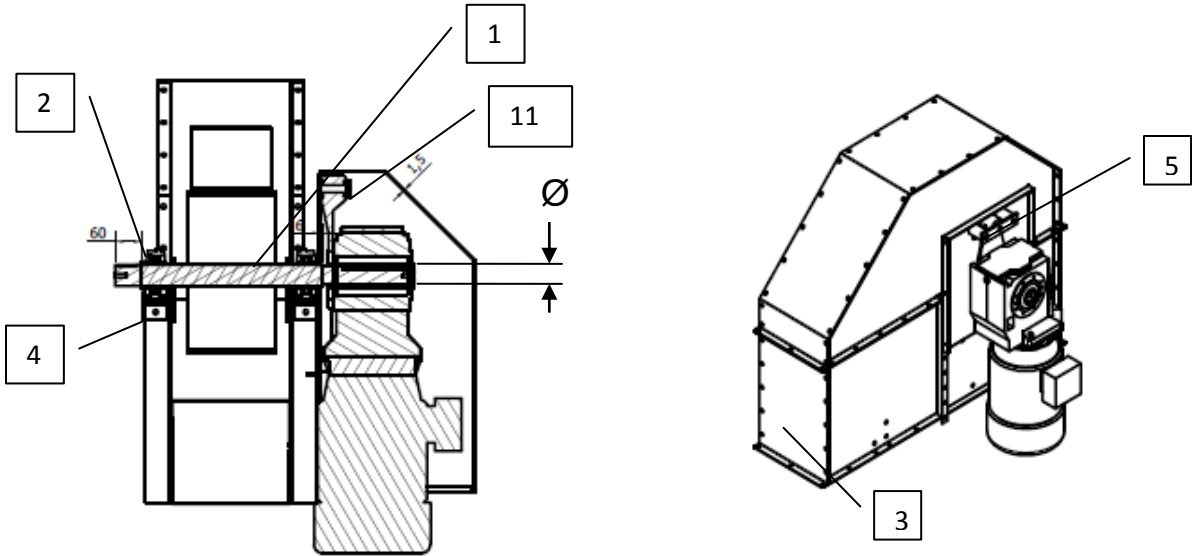

Bucket elevator boot

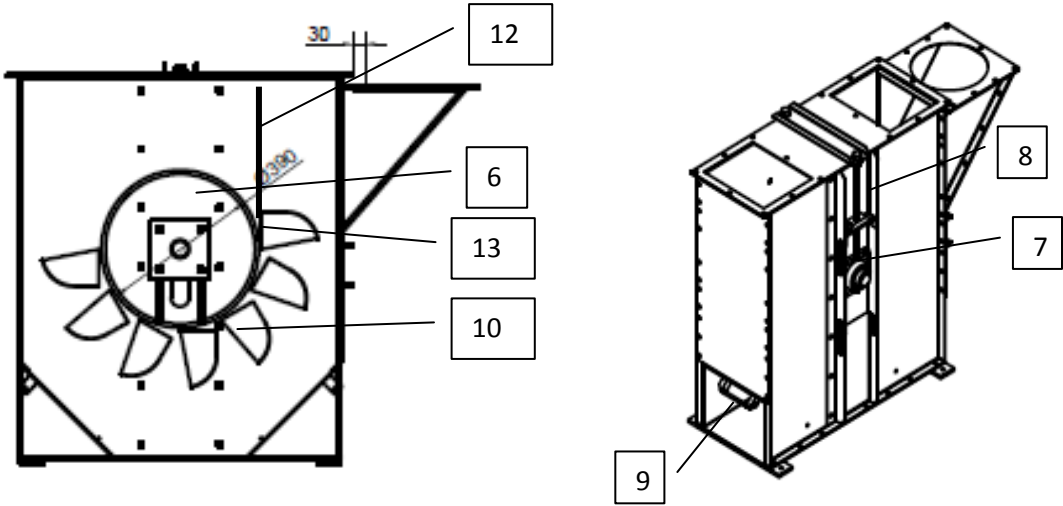

## KBE 60/80 Bucket Elevator – Spare Parts list.

	Part no.	Description	Ø	Pos.
KBE 60/80 Elevator head	136000556	KBE 60/80 Belt pulley elevator head w. Shaft Ø35	35	1
	92503006	KBE 60/80 Belt pulley elevator head w. Shaft Ø40	40	1
	136000557	KBE 60/80 Belt pulley elevator head w. Shaft Ø50	50	1
	136000558	KBE 60/80 Belt pulley elevator head w. Shaft Ø60	60	1
	136000522	KBE 60/80 Bearings for elevator head SY 50 TF, 2 pc's		2
	136000559	KBE 60/80 Front plate for elevator head		3
	136000560	KBE 60/80 Bracket for back running stop		4
	92831137	KBE 60/80 Bracket for torque arm gear drive Ø35	35	5
	136000561	KBE 60/80 Bracket for torque arm gear drive Ø40	40	5
	136000562	KBE 60/80 Bracket for torque arm gear drive Ø50	50	5
136000563	KBE 60/80 Bracket for torque arm gear drive Ø60	60	5	
KBE 60/80 Elevator boot	136000518	KBE 60/80 Belt pulley with shaft boot		6
	136000517	KBE 20/120 Bearings flange boot FY 40 TF, 2 pc's		7
	136000564	KBE 60/80 Spindle for belt tightening		8
	136000565	KBE 60/80 Cleaning door		9
KBE 60/80	136000431	KBE 60/80 Bucket steel		10
	136000432	KBE 60/80 Bucket plastic HDP/MD		10
	100505165	KBE 60/80 Torque arm gear motor. For shaft Ø35	35	11
	100505166	KBE 60/80 Torque arm gear motor. For shaft Ø40	40	11
	100505160	KBE 60/80 Torque arm gear motor. For shaft Ø50	50	11
	100505161	KBE 60/80 Torque arm gear motor. For shaft Ø60	60	11
	136000444	KBE 60 Belt standard 8 buckets/m		12
	136000445	KBE 60 Belt oil resistant 8 buckets/m		12
	136000429	KBE 80 Belt standard 10,5 buckets/m		12
	136000430	KBE 80 Belt oil resistant 10,5 buckets/m		12
	136000494	KBE 60/80 Bolt & nut & washer 100 Pc's		13