

KBE 20/40 Bucket Elevator – Spare Parts list.

Bucket elevator head.

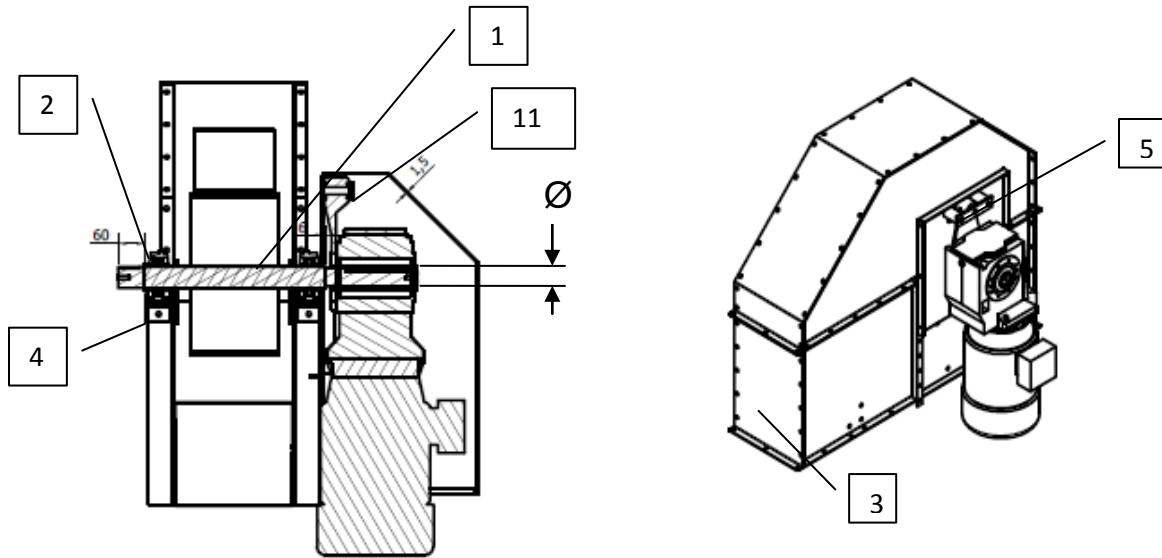

Bucket elevator boot

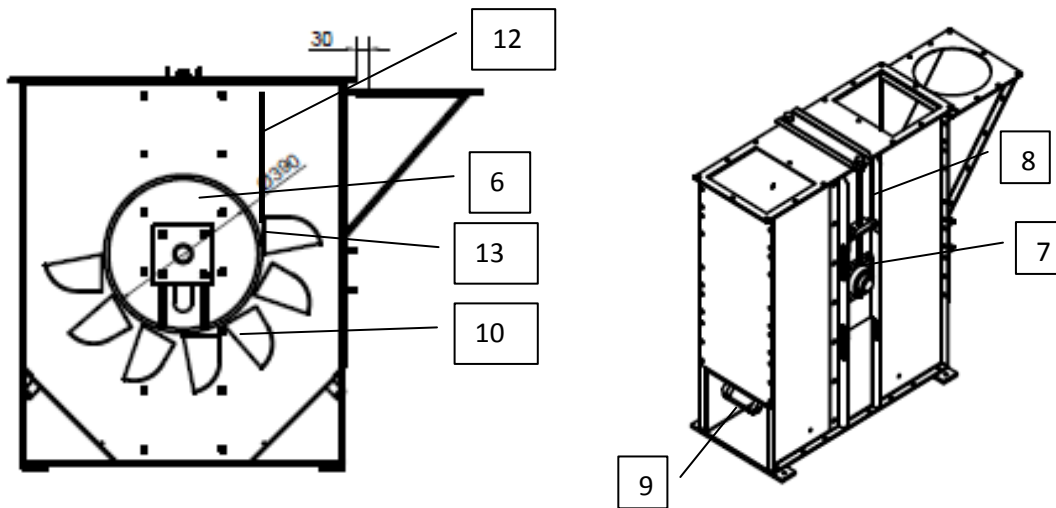

KBE 20/40 Bucket Elevator – Spare Parts list.

Part no.	Description		Ø	Pos.
136000535	KBE 20/40	Belt pulley elevator head w. Shaft Ø25	25	1
136000513	KBE 20/40	Belt pulley elevator head w. Shaft Ø30	30	1
136000536	KBE 20/40	Belt pulley elevator head w. Shaft Ø35	35	1
136000550	KBE 20/40	Belt pulley elevator head w. Shaft Ø40	40	1
136000516	KBE 20/40	Bearings for elevator head SY 40 TF, 2 pc's		2
136000551	KBE 20/40	Front/wear plate for elevator head		3
92830137	KBE 20/40	Bracket for back running stop		4
136000540	KBE 20/40	Bracket for torque arm gear drive Ø25	25	5
92804001	KBE 20/40	Bracket for torque arm gear drive Ø35	35	5
136000552	KBE 20/40	Bracket for torque arm gear drive Ø30	30	5
136000553	KBE 20/40	Bracket for torque arm gear drive Ø40	40	5
136000511	KBE 20/40	Belt pulley with shaft boot		6
136000517	KBE 20/120	Bearings flange boot FY 40 TF, 2 pc's		7
136000554	KBE 20/40	Spindle for belt tightening		8
136000555	KBE 20/40	Cleaning door		9
136000407	KBE 20/40	Bucket steel		10
136000408	KBE 20/40	Bucket plastic HDP/MD		10
100505164	KBE 20/40	Torque arm gear motor. For shaft Ø25	25	11
100505165	KBE 20/40	Torque arm gear motor. For shaft Ø35	35	11
100505165	KBE 20/40	Torque arm gear motor. For shaft Ø30	30	11
100505166	KBE 20/40	Torque arm gear motor. For shaft Ø40	40	11
136000405	KBE 20/40	Belt standard 6/12 buckets/m		12
136000406	KBE 20/40	Belt oil resistant 6/12 buckets/m		12
136000494	KBE 20/40	Bolt & nut & washer 100 Pc's		13