

KBE 100/120 Bucket Elevator – Spare Parts list.

Bucket elevator head.

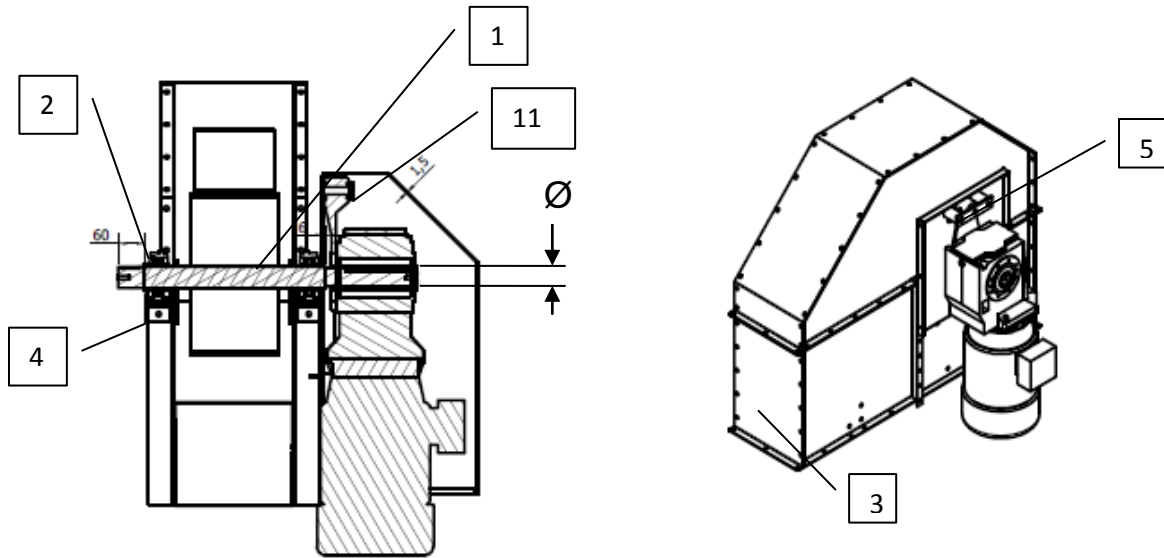

Bucket elevator boot

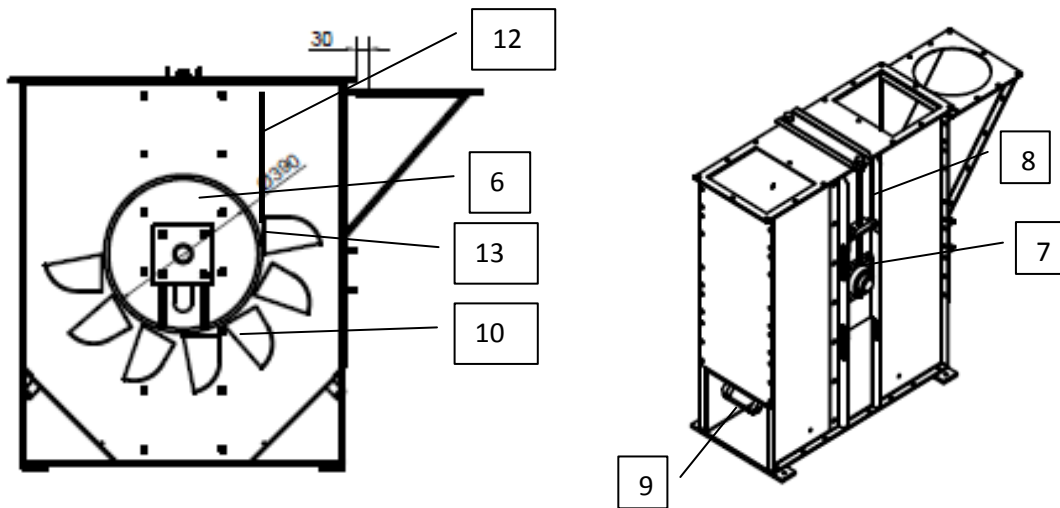

KBE 100/120 Bucket Elevator – Spare Parts list.

Part no.	Description		Ø	Pos.
136000566	KBE 100/120	Belt pulley elevator head w. Shaft Ø40	40	1
136000567	KBE 100/120	Belt pulley elevator head w. Shaft Ø50	50	1
136000526	KBE 100/120	Belt pulley elevator head w. Shaft Ø60	60	1
136000528	KBE 100/120	Bearings for elevator head SY 60 TF, 2 pc's		2
136000568	KBE 100/120	Front – wear plate for elevator head		3
92832137	KBE 100/120	Bracket for back running stop		4
136000569	KBE 100/120	Bracket for torque arm gear drive Ø40	40	5
136000570	KBE 100/120	Bracket for torque arm gear drive Ø50	50	5
136000571	KBE 100/120	Bracket for torque arm gear drive Ø60	60	5
136000524	KBE 100/120	Belt pulley with shaft boot		6
136000517	KBE 20/120	Bearings flange boot FY 40 TF, 2 pc's		7
136000573	KBE 100/120	Spindle for belt tightening		8
136000574	KBE 100/120	Cleaning door		9
136000479	KBE 100/120	Buckets steel		10
136000480	KBE 100/120	Buckets plastic HDP/MD		10
100505166	KBE 100/120	Torque arm gear motor. For shaft Ø40		11
100505160	KBE 100/120	Torque arm gear motor. For shaft Ø50		11
100505161	KBE 100/120	Torque arm gear motor. For shaft Ø60		11
136000475	KBE 100	Belt standard 7,5 buckets/m		12
136000476	KBE 100	Belt oil resistant 7,5 buckets/m		12
136000477	KBE 120	Belt standard 9 buckets/m		12
136000478	KBE 120	Belt oil resistant 9 buckets/m		12
136000481	KBE 100/120	Bolt & nut & washer 100 Pc's		13