

Fanguard

Suction blower

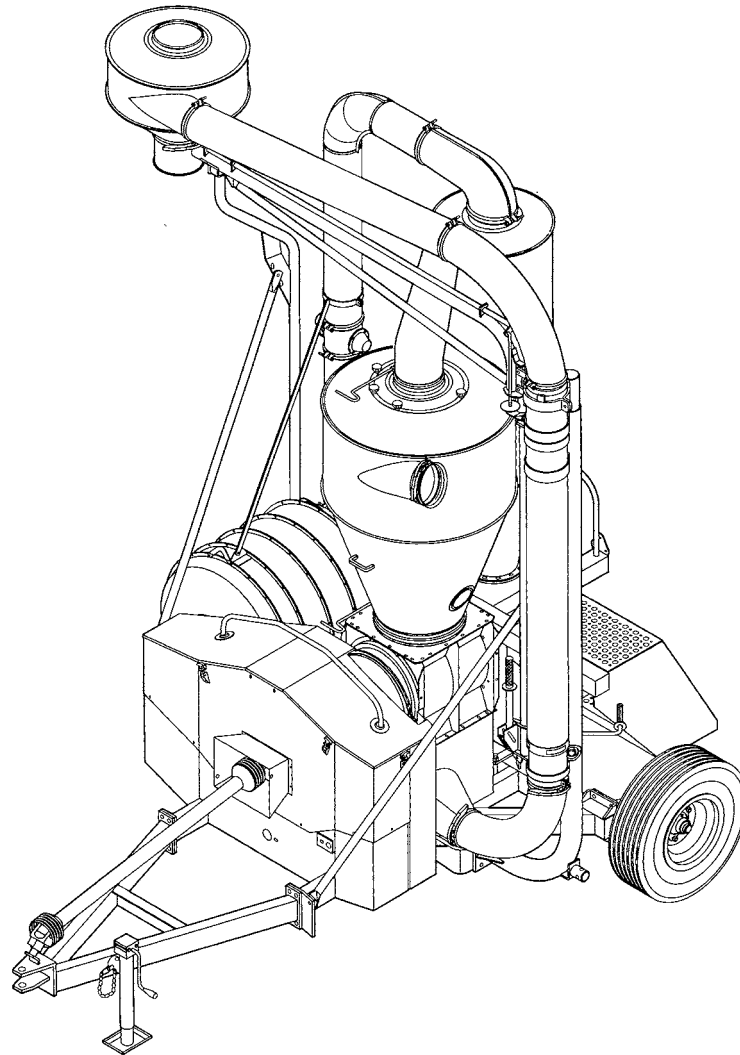

Assembly instructions & Spare parts list

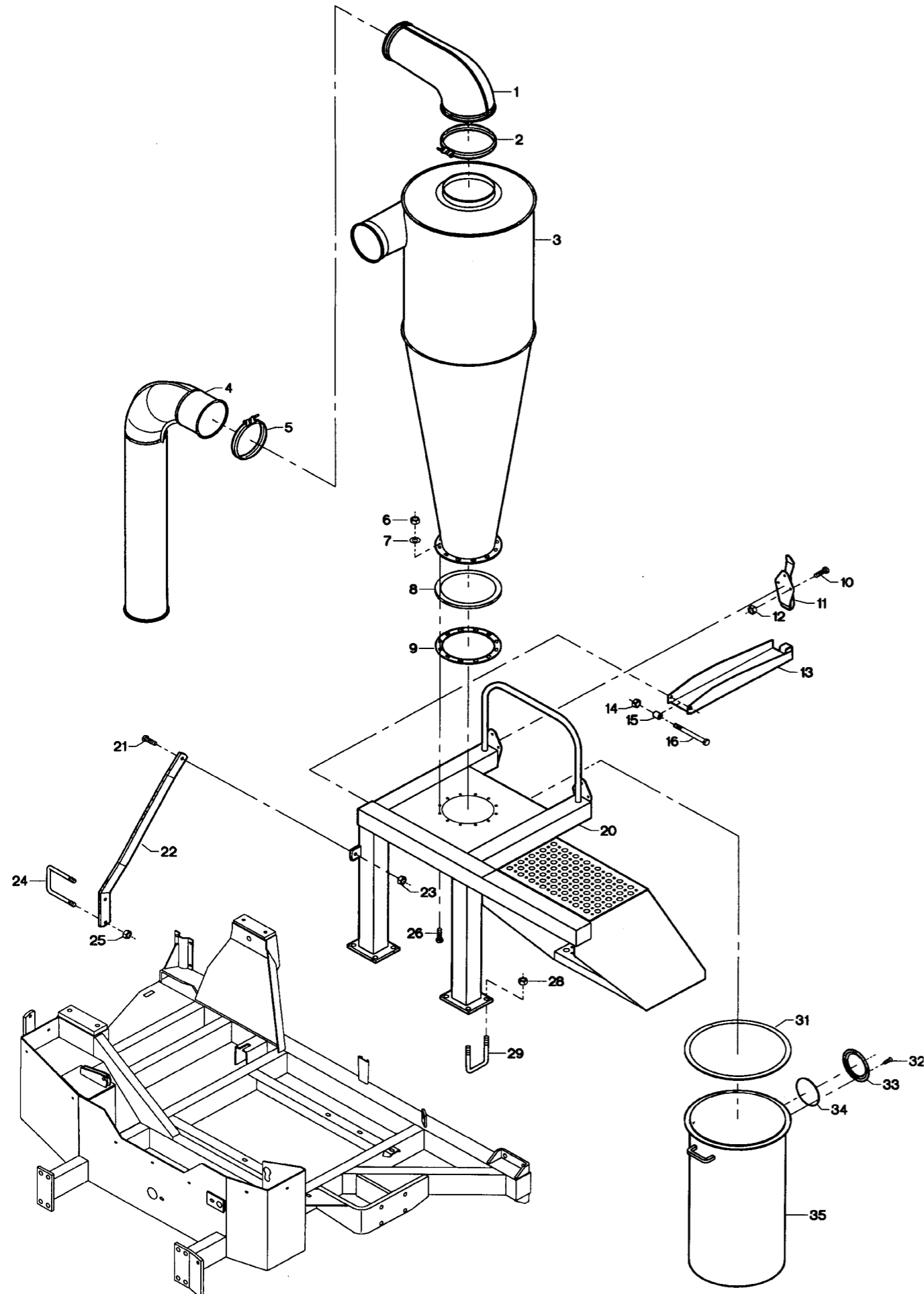
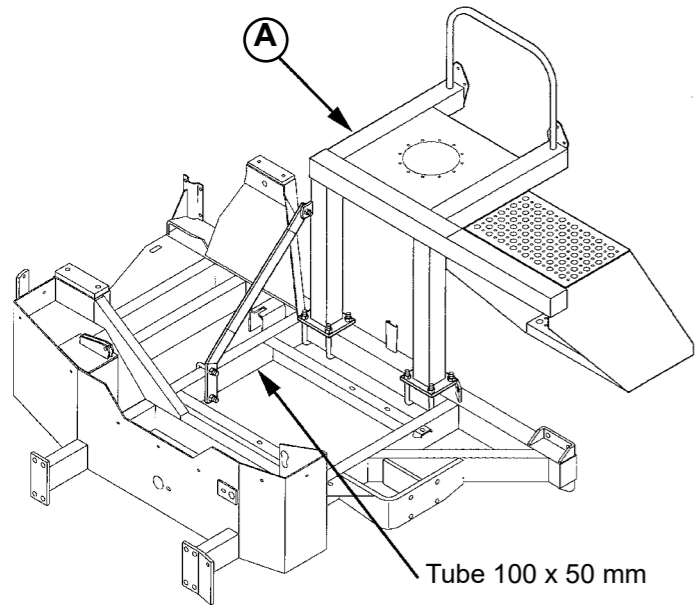
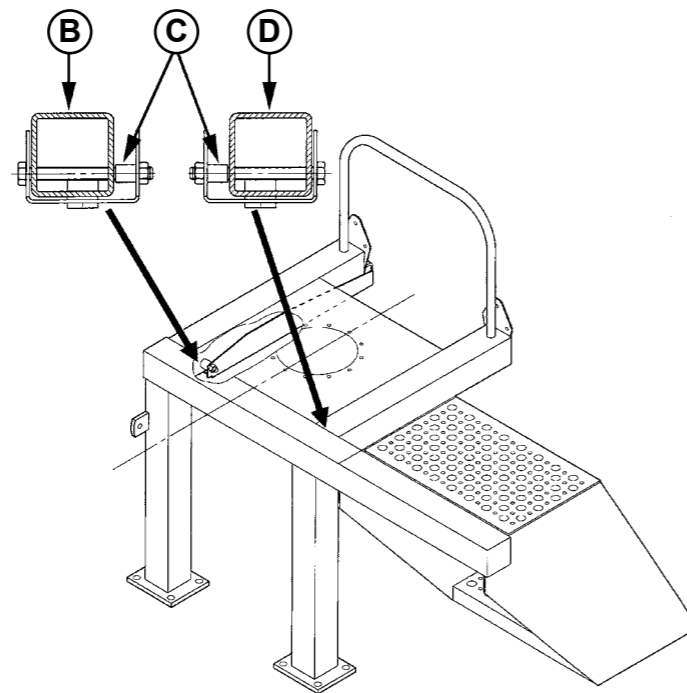

Fig.	Part no.	Pieces	Notes
1	121 140 175	1	
2	122 050 110	1	Clamp with bolt OK200
3	121 150 317	1	
4	121 150 291	1	
5	122 000 825	1	Clamp with bolt OK160
6	100 316 003	12	Lock nut M8
7	100 331 005	12	Flat washer M8
8	100 202 024	-	10 x 8 mm, Order 1.4 m
9	121 150 329	1	
10	100 306 015	6	Set screw M8 x 20 mm
11	100 323 367	2	
12	100 316 003	6	Lock nut M8
13	121 150 309	2	
14	100 316 005	2	Lock nut M12
15	105 000 410	2	ø17/13 x 20 mm
16	100 306 073	2	Set screw M12 x 130 mm
20	121 150 295	1	
21	100 304 033	1	Set screw M12 x 35 mm
22	121 150 305	1	
23	100 316 005	1	Lock nut M12
24	108 000 124	1	M12
25	100 316 005	2	Lock nut M12
26	100 309 019	12	Screw M8 - 35 mm
28	100 316 006	8	Lock nut M16
29	121 150 294	4	M16
31	100 202 046	-	10 x 12 mm, Order 1,15 m
32	100 323 011	4	Selv-tapping screw 4.2 x 8 mm
33	121 000 089	1	
34	121 000 090	1	
35	121 150 312	1	

Assembling the Fanguard



Mount the platform (A) on the frame of the SUC 1000 suction blower as shown. Place the U-bolt for fixing the platform as close to the 100 x 50 mm tube as possible.



Mount the two bolt arms (B), holding the waste basket. Remember to mount the spacing pieces (C) as shown.

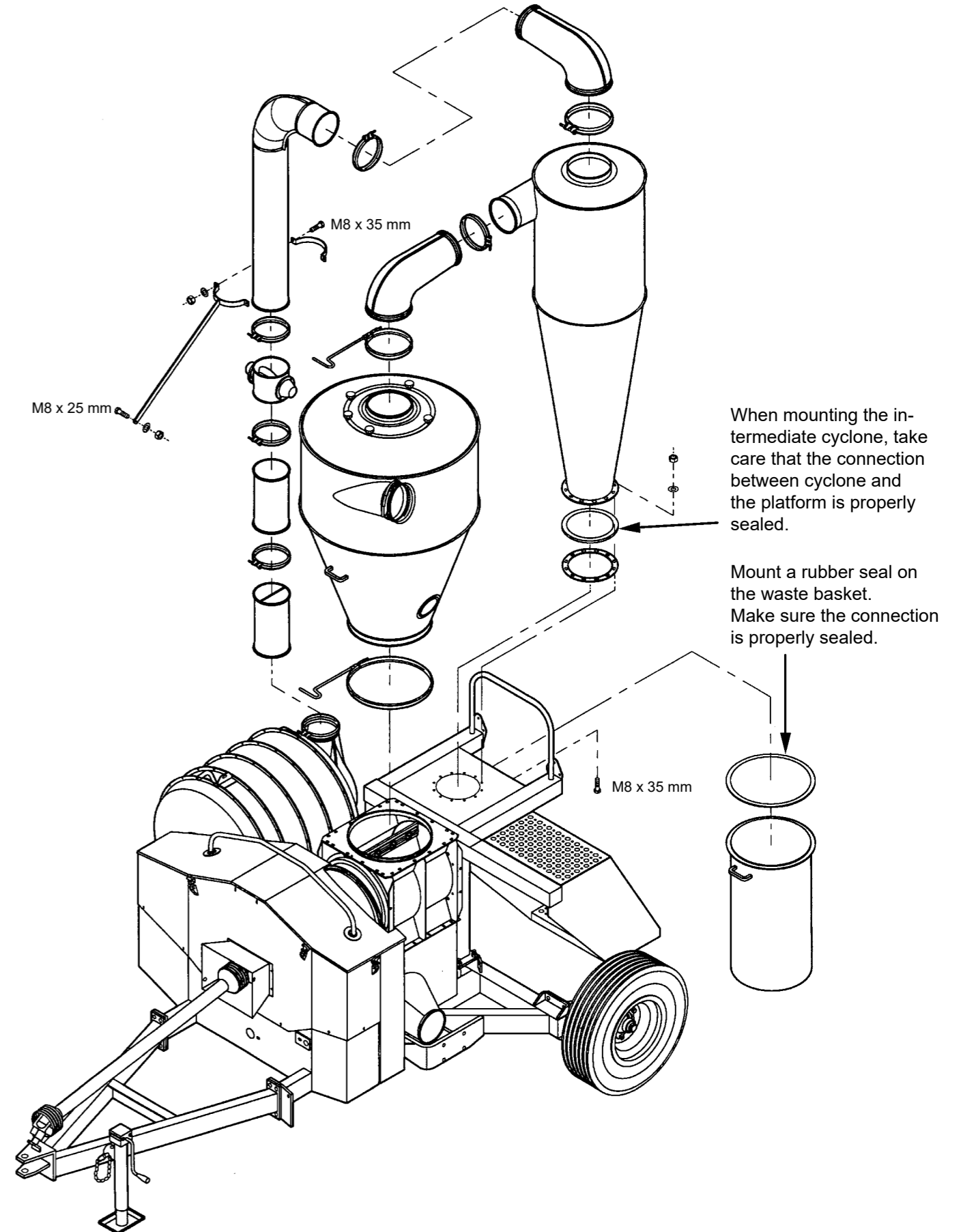
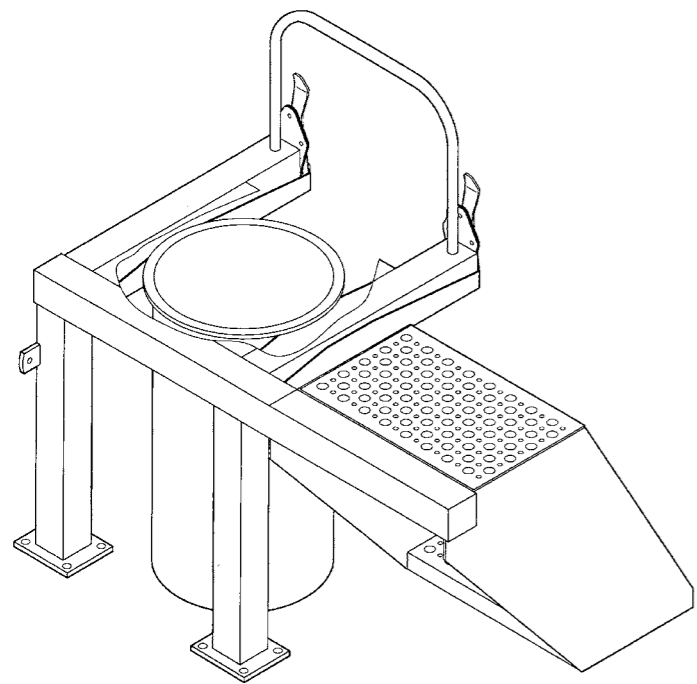

Kongskilde Industries A/S

Skælskørvej 64

DK - 4180 Sorø

Tel. +45 72 17 60 00

mail@kongskilde-industries.com

www.kongskilde-industries.com