



Pneumatic Cleaning and Conveying Solutions



Your Grain Cleaning & Conveying Specialists

Since 1949 Kongskilde Industries has been providing trusted solutions for the handling and cleaning of grain and seed. We are pioneers within the field of conveying blowers for many different kinds of material handling needs. Our systems are quick, efficient, environment friendly, and gentle on the grain.

At Kongskilde, our dedicated and experienced staff ensure that all products and solutions are customer focused in regards to development, testing,

production and installation. Our reliable and scalable solutions are designed in close cooperation with our customers, who always have the last say.

Dialogue is the first step towards the best Kongskilde solution; you tell us your company needs - now and in the future. Start the conversation today and discover what the power of air can do for your business.

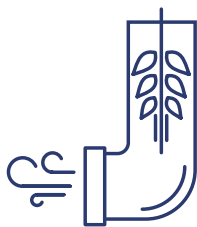

**CONVEYING
PNEUMATICALLY**

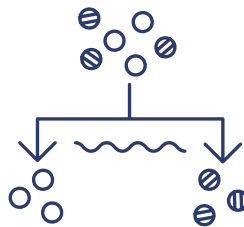

**CLEANING AND
SEPARATION**



**WEIGHING
SOLUTIONS**

QUESTIONS? GET IN TOUCH WITH US

✉ kna@kongskilde-industries.com

☎ (309) 452-3300

🌐 www.kongskilde-industries.com

📱 [@kongskildegrain](https://www.facebook.com/kongskildegrain)

FRL 15 Aspirator Fan



Improves Grain Quality and Reduces Cost

The FRL 15 Aspirator Fan is an effective, economical way to give your grain an air wash and remove any light, unwanted foreign materials like dust and bees' wings (red dog). Plus, its adaptability makes it a great addition to your operation. Add it to the discharge on grain dryers or place it at the head or boot of grain elevator legs or augers... and let it clean away!

4 Reasons to Clean Your Grain

- **Improves Grain Quality**
Let's face it. Prices at the elevator matter. By removing these unwanted materials, you improve your FM counts and reduce dockage at the elevator.
- **Improves Aeration**
Another great benefit is that with the fines removed, air circulation is also improved in storage facilities without overtaxing aeration fans. Goodbye hot spots and spoilage!
- **Eliminates Plugging**
Bees' wings are known for plugging up systems. By removing them from your grain, you can add downspouts to legs without worrying about clogging and downtime.
- **Prolongs Equipment Life**
The cleaner you keep your equipment, the longer it lasts. Removing bees' wings and other contaminants to a bin keeps your processing area clean and working at peak performance.

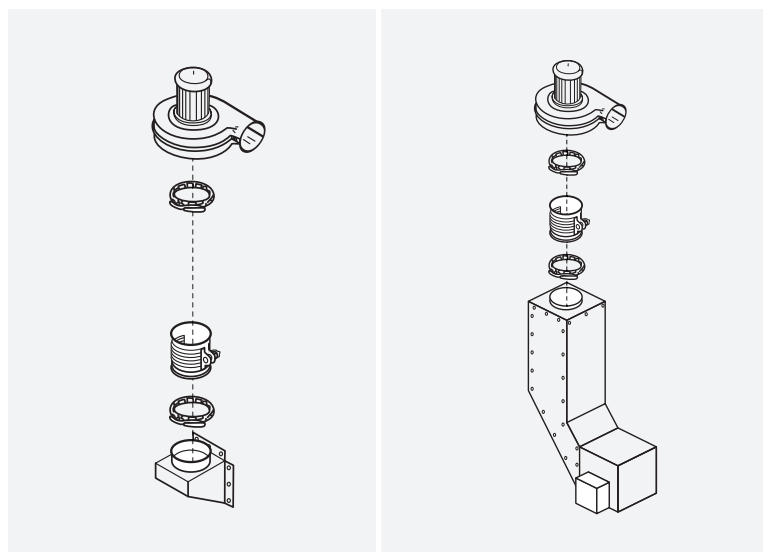

Universal Mount

M-C Mount

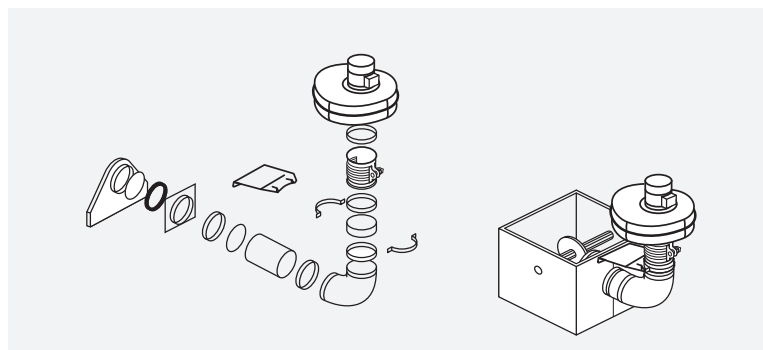

Super B Conveyor Mount

Dual Cleaner **KDC PLUS**

The KDC is a cleaner with a dual cleaning function that utilizes both screen and aspirator technology. The screens sort the grain by means of size, and the aspirator unit removes light impurities and dust by means of air for exceptional cleaning capability.

The KDC Plus features hinged doors for complete access to screens for easy screen replacement and visual inspection from either side. The inner screen serves as scalping, removing all large particles, and the total outer screen area is available for smaller fines removal.

The KDC Plus 4000 has a capability of up to 1,400 bu/h (40 t/h). The KDC Plus 8000 can handle twice as much with a capability of up to 2,800 bu/h (80 t/h).



KDC 8000 PLUS



Bottom of inlet made of heavy stainless steel for weather resistance.



Easy access for collection of grain samples after cleaning.



Windows on the side panel and aspirator unit can easily be cleaned or replaced.

Features & Benefits

- Effective size separation of grain kernels through two layers of screens.
- Quick-release system for easy and fast replacement of screens.
- Large selection of screens for all common crops.
- Cleaning by aspiration after size screening for maximum removal of dust.
- Limited stress and wear of cleaner with rotative parts only, so no vibration is transmitted.
- All components exposed to the ambient are made in galvanized steel suited for outdoor installations.
- Wear spots are made in stainless steel.
- Dampers on the torque arm for gear drive reduce stress load on screen drum.
- A vacuum inside the drum compartment limits the amount of dust.
- Easy adjustment of screen drum angle by use of crank handle (standard on KDC 8000 PLUS).
- Easy access for collection of grain samples after cleaning.
- Easy inspection during operation through multiple windows.

How a KDC Works



KDC 4000 **PLUS**

Parameters Affecting Capacity

- Grain type and condition, moisture, impurities.
- Higher inclination of the adjustable legs makes the grain pass faster over the screens. This provides a higher capacity, but reduces the cleaner's effectiveness.
- Selection of screens. Inner screens with "small" holes provide a better cleaning at a lower capacity.
- How the cleaner is installed.

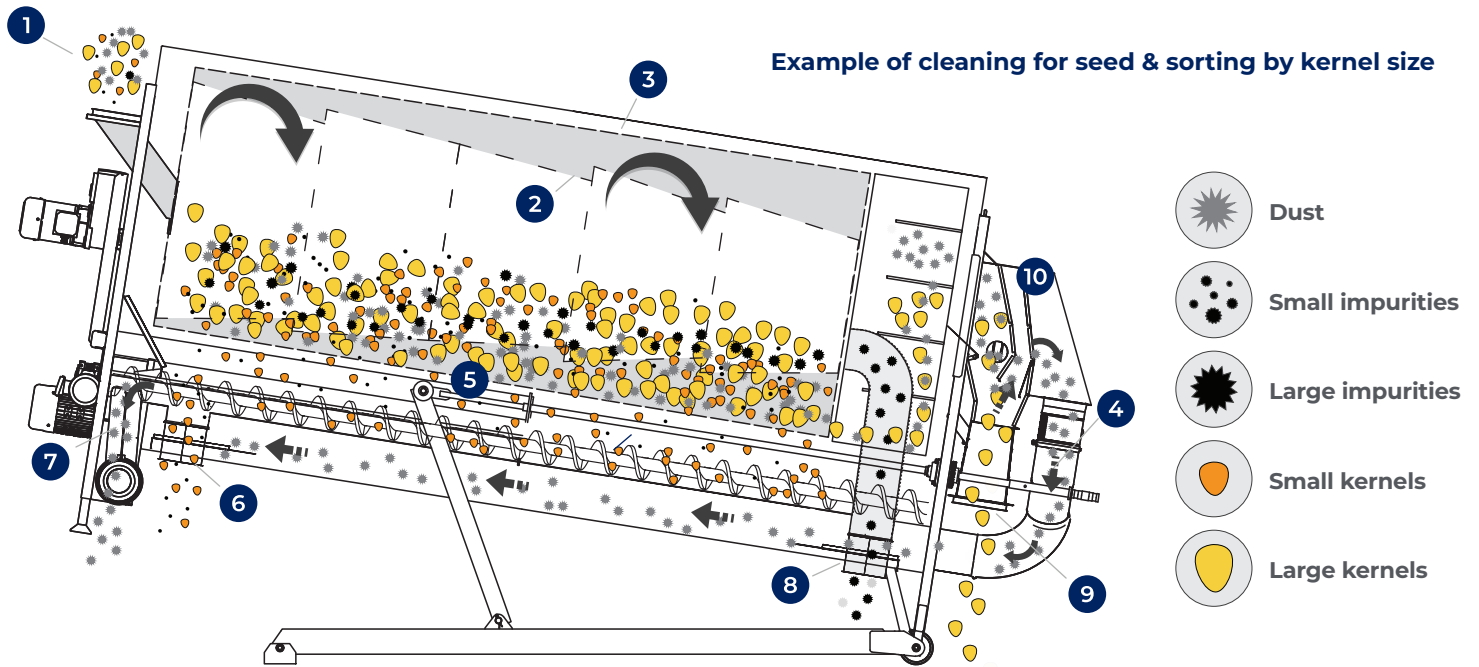



KDC 8000 **PLUS**



Aspiration Cleaning

The aspirator unit is placed at the end of the cleaning system and is used to separate light impurities and dust from the grain.



Easy to open side panels save time when changing screens



Screenings are conveyed through pipes up to 15 m (50 ft) away



The cleaning brushes are mounted on a spring loaded arm for efficient even load on the outer screens



A quick-release system makes it easy and fast to change screens and make ready for the next crop

Accessories

- Wide assortment of standard screens for all common crops.
- Cleaning brushes clean the outer screens.
- Rain cover for motors and gear boxes.
- OK 200 pipe system and cyclone, connected to the outlet of the aspirator blower for conveying of trash and fines.
- Wheel set for short distance transport of KDC 4000/8000 PLUS between different locations.

Screens

Kongsilde Industries offers a large assortment of screens for size separation of grain kernels. See Datasheet "Screen Selection for KDC" for more details.

Technical specifications	KDC 4000 PLUS	KDC 8000 PLUS
Max. capacity pre-cleaning. t/h*	40	80
App. capacity seed cleaning. t/h*	3 - 17	6 - 34
App. capacity malting barley. t/h*	3 - 17	6 - 34
Screen drum drive motor size kW (HP)	1.5 (3.0)	2.2 (3.0)
Screen drum RPM	21.9	23
Blower for aspirator motor size kW (HP)	4.0 (5)	4 (5)
Blower for aspirator motor. RPM	3.450	3.450
Auger drive motor size. kW (HP)	0.75 (1.5)	1.1 (1.5)
Auger RPM	3.450	1.750
Inlet for crop	OK 200 (8")	FK 250 (10")
Outlet for cleaned crop	OK 200 (8")	FK 250 (10")
Conveying pipes for impurities	OK 200 (8")	OK 200 (8")
Pipe outlet from auger	OK 160 (6")	OK 200 (8")
Screen area. Inner drum. m ²	4.1	7.5
Screen area. Outer drum. m ²	6.5	10
Weight. machine without screens. lbs (kg)	1,962 (890)	3,141 (1,425)

*Grain 700 kg/m³. Capacity affected by grain type and condition, moisture, impurities, angling of KDC, selection of screens

Screen Selection for KDC Plus

Inner Screen

KDC Plus 8000

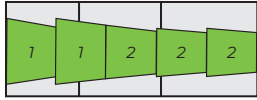

KDC Plus 4000

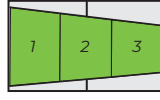

Max. capacity



Max. cleaning eff. - reduced capacity

Regarding capacity and selection of inner screens

The inner screen separates the large fines from the crop. Inner screen with small holes compared to the kernel size gives the most efficient cleaning, but reduces the capacity. Inner screen with large holes compared to the kernel size gives capacity, but reduces the cleaning efficiency. If too much crop is fed into the KDC, good kernels will be discharged together with the fines.

Screen Perforation in Sections (mm)	Corn	Wheat	Barley	Oats	Rye	Soybeans	Sunflower seeds	Peas	Canola
KDC 8000 Plus1-1-2-2-2 KDC 4000 Plus1-2-3									
●17 ●17 ●15 ●15 ●15 ●17 ●17 ●15									
●15 ●15 ●13 ●13 ●13 ●15 ●15 ●11									
●13 ●13 ●11 ●11 ●11 ●13 ●13 ●11									
●11 ●11 ●9 ●9 ●9 ●11 ●11 ●9									
●9 ●9 ●7.4 ●7.4 ●7.4 ●9 ●9 ●7.4									
●8 ●8 ●7.4 ●7.4 ●7.4 ●8 ●7.4 ●7.4									
●7.4 ●7.4 ■5.2 ■5.2 ■5.2 ●7.4 ●7.4 ■5.2									
●7 ●7 ■5.2 ■5.2 ■5.2 ●7 ■5.2 ■5.2									
●6.5 ●6.5 ■5.2 ■5.2 ■5.2 ●6.5 ■5.2 ■5.2									
■5.2 ■5.2 ●4.3 ●4.3 ●4.3 ■5.2 ■5.2 ●4.3 ●4.3									
●4.3 ●4.3 ●3.5 ●3.5 ●3.5 ●4.3 ●4.3 ●3.5									
●3.5 ●3.5 ■2.75 ■2.75 ■2.75 ●3.5 ●3.5 ■2.75									
—10 x 30 (all sections)									
—5 x 20 (all sections)									
—3.5 x 16.5 (all sections)									

●Round Holes ■Square Holes —Oblong Holes

Outer Screen

KDC Plus 8000



KDC Plus 4000



Kernel Size

- Small
- Middle
- Large

Regarding capacity and selection of outer screens

On the outer screen small fines and kernels are separated from the crop. For pre-cleaning there is no limitation in capacity in relation to screen choice. For size separation of kernels on the outer screen approx. 10-20% of the capacity rated for pre-cleaning can be obtained.

Screen Perforation (mm)	Corn	Wheat	Barley	Oats	Rye	Soybeans	Sunflower seeds	Peas	Canola
KDC 8000 3 screen modules - all identical KDC 4000 2 screen modules - both identical									
—1.0 x 16.5									●
—1.2 x 16.5									●
—1.4 x 16.5		●			●				
—1.8 x 16.5		●			●		●		
—2.0 x 16.5		●	●				●		
—2.25 x 16.5		●	●				●		
—2.4 x 16.5		●	●						
—2.5 x 16.5			●						
—2.65 x 16.5			●						
—3.5 x 16.5						●			
—4.0 x 16.5						●		●	
—4.3 x 16.5						●		●	
—4.5 x 16.5						●		●	
—5.0 x 20.0	●								
■2.75		●	●		●				
■5.2	●								
■6.0	●								
●2.0		●	●	●	●				
●3.5						●		●	
●4.3	●					●		●	
●7.0	●								
●7.4	●								
●9.5	●								
No perforation									

Kongskilde Aspirators KF

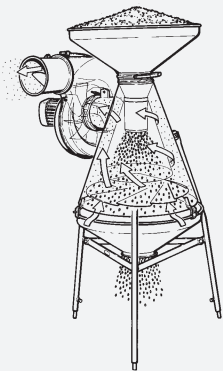

KF 12 mode of operation.



KF 12 Aspirator model.

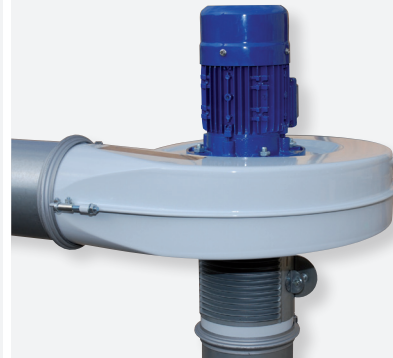

FRL 15 blower can be used to vacuum off dust, fines, and chaff at grain dryer discharge or at leg, auger, and conveyor inlets.



Cyclone for discharge of dust.

How An Aspirator Works

The grain passes through an upwards moving air stream in the aspirator. The air stream picks up dust and light impurities, and gravity allows the grain to fall down into the bottom outlet of the aspirator.

The dust and light impurities follow the air stream through the blower and further on into a pipeline to the desired discharge point.

Aspirators are suited for removal of dust and light impurities from grain. The construction of the pre-cleaner provides many options for integration in a grain plant.

We recommend that the grain cleaner is installed in such a way that it can clean the grain both before going into and coming out of storage.





KF 40 mode of operation.



KF 40 fitted with support legs.



Air regulator for adjustment of the suction power of the aspirator blower.

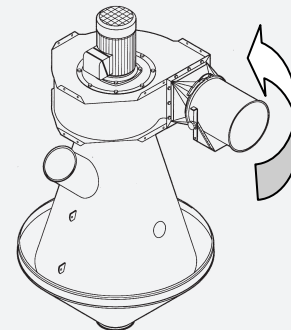

Blower outlet can be turned in any direction.

Benefits

- Modular system with great flexibility for built-in systems.
- Cost effective way to clean grain before going into storage or coming out.

Technical specifications	KF 12	KF 20	KF 60
Max. capacity (barley) t/h	12	20	60
Motor size blower motor kW (HP)	0.75 (1.5)	1.5 (3.0)	7.5 (10)
Motor RPM	3,450		
Motor type	C Flange motor		
Weight (incl. motor) lbs (kg)	165 (75)	232 (105)	573 (260)
Conveying pipes for fines	OK 160	OK 200	2 x FK 300
Max. recommended conveying length for fines ft (m)	80 (25)	50 (15)	50 (15)

KIA Aspirator Fan



KIA aspirator cleaning process.



KIA 20 Aspirator model.

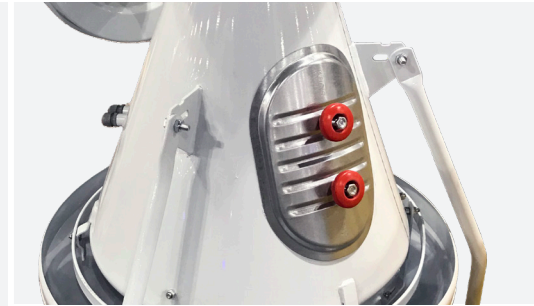

Inspection hatch on KIA

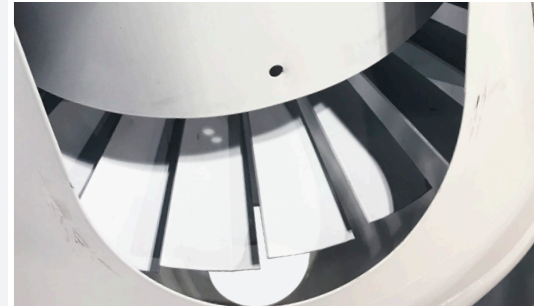

Open KIA inspection hatch showing distributor inside.

Aspiration Cleaners

The KIA is designed to separate light impurities or dust from all types of grain. The capacity of the Aspirators will vary depending on the kind of grain being cleaned.

Using the aspiration principle, the grain falls through an upward moving air stream generated by a blower which is mounted on the Aspirator. The lighter impurities are drawn up by the air stream through the blower and conveyed through a pipe system into a cyclone or a container, while the clean grain falls through the bottom of the Aspirator.

A rotating distributor table in the bottom part of the Aspirator ensures that the material is evenly distributed in the air stream. This provides maximum cleaning efficiency.

Optional equipment for the KIA 20 and 60 includes a motor for the distributor table, which ensures a constant rpm. When the motor rpm is managed by frequency control, the cleaning performance is considerably increased as the material is more evenly distributed in the Aspirator.

Technical specifications	KIA 12	KIA 20	KIA 60
Capacity, bu./hour (corn)	425	715	2000
Motor output, HP	1.5	3.0	10.0
Motor speed, RPM	3450	3450	3450
Weight incl. motor, lbs	92	233	572
Pipe dimension of fan	OK 160	OK 200	FK 300

Please note that the indicated capacities are intended as guidelines. To obtain the exact capacity of a given installation, Kongskilde offers to test the specific material which is to be cleaned.

MTD Blowers



MTD Blowers are direct drive centrifugal units designed for material through handling.

MTD blowers are equipped with a self cleaning rotor, with 6 backwards curved blades and an aerodynamic intake. The rotor is statically and dynamically balanced to ensure maximum airflow and efficiency. The MTD blower is ideal for removing fines as grain is transferred to or from storage.

A volume of up to 7,000 CFM and a max pressure of 18" pt. inches WG can be reached.

Benefits

- MTD blower houses are constructed in 3mm steel plate.
- Suited for both indoor and outdoor installation.
- Low power consumption.

Technical Data

Type	Motor MP	Rpm	Weight lbs (kg)	Noise level 3' (1m) dBA	Standard inlet
MTD 20	2	3450	90 (41)	74	OK160 (6")
MTD 22	3	3450	119 (54)	73	OK200 (8")
MTD 25	5	3450	168 (76)	76	OK200 (8")
MTD 30	10	3450	236 (107)	80	FK 250 (10")
MTD 35	15	3450	421 (191)	80	FK 250 (10")
MTD 40	30	3450	624 (283)	84	FK 250 (10")

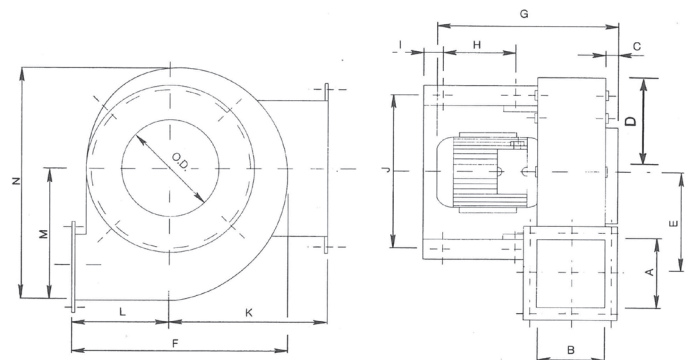

Type	A mm	B mm	C mm	D mm	D1 mm	øD2 mm	n mm	E mm	F mm	G mm	H mm	I mm	J mm	K mm	L mm	M mm	N mm
MTD 20	140	85x2	33	200	235	9	12	207	448	406	141	40	329	325	198	284	500
MTD 22	166	98x2	29	225	260	9	12	220	500	475	192	40	326	340	224	310	552
MTD 25	186	108x2	30	250	285	9	12	248	582	530	210	50	356	384	273	348	618
MTD 30	206	118x2	36	300	335	9	12	267	631	644	230	50	356	415	293	377	676
MTD 35	225	128x2	45	350	389	11	12	320	670	740	360	50	390	515	293	438	770
MTD 40	250	94x3	55	400	439	11	12	330	740	810	400	50	488	500	326	462	824

K-Series Bag Filter



The Superbag polyester fiber bags for dust collection.



Barrels waste disposal option.



Dump bin waste disposal option.



Bags waste disposal option.

Modular Dust Collection

The K-Series bag filter is a modular dust collection unit ideal for indoor installations. The K-Series dust collector is an enclosure-less, compact and simple-to-set-up dust collector.

Waste collection is available in the form of bags, barrels, or a dump bin. The disposal bin clamps securely into place to prevent dust from escaping. The clamps are easily removed for quick disposal of waste.

The Superbag

The Superbag is a polyester filter bag created using a patented weaving technique in tubular format. This design gives the filter bag a surface which can cope with varying dust loads and with virtually any type of dust.

Benefits

- Special shape ensures high efficiency and effectiveness over long periods of time.
- Durable patented construction made from strong polyester fiber and seamless body.
- Efficient filter media provides low pressure drop and low energy consumption.
- Interwoven carbon fiber wire provides anti-static properties inside and out.
- Easy assembly.

KA Batch Weighers



KA batch weigher trip mechanism.

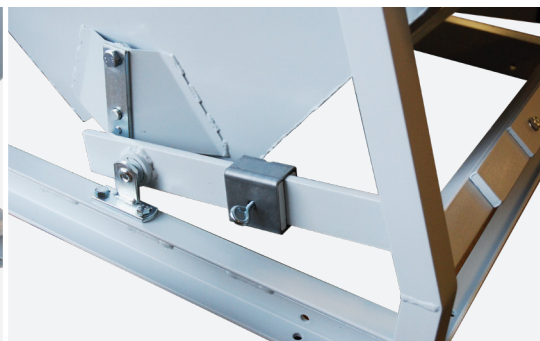

KA batch weigher adjustment.



KA batch weigher mechanical counter.

Simple and Robust

Kongskilde twin-compartment batch weighers operate on a continuous batch weighing principle, in which the material flows constantly through the weigher at a given capacity.

Benefits

- Robust and simple construction ensures reliable operation.
- Suited to many different applications, such as cereals and other granular materials.

Weigher Type	KA 10	KA 25
Contents per comp. std. lbs (kg)	22 (10)	55 (25)
Contents per comp. min/max lbs (kg)	13-26.5 (6-12)	44-66 (20-30)
Capacity t/h (dry barley)	8	15
Volume per compartment, litres	26	68
Net weight, lbs (kg)	66 (30)	115 (52)
Accuracy deviation (subject to correct adjustment and operation)	+/-1%	+/-1%

**All weighers are balanced at the factory to weigh out the batch indicated. If desired, the weight may be varied within the limits stated above.*

High Pressure Blowers TRL

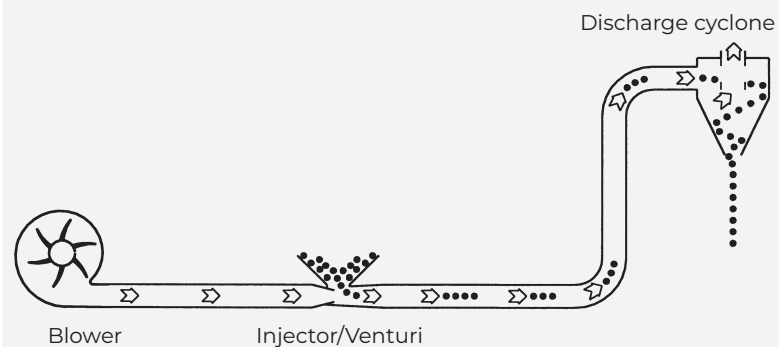
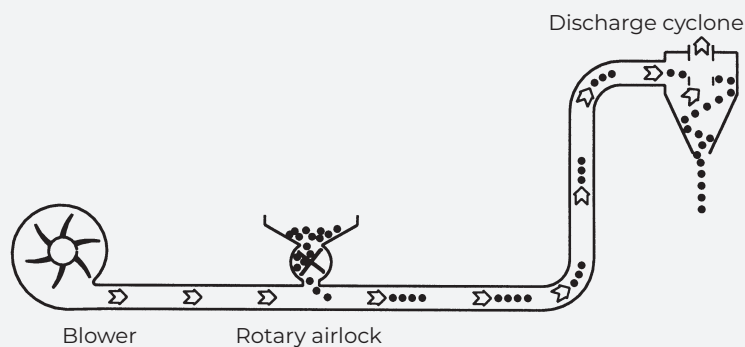

You've got grain here. You need grain there. How should you move it?

Our Kongskilde TRL blowers offer highly customized solutions to moving grain from A to B and beyond. TRL blowers are available from 3 to 100 hp. Some TRL blower models can use several sizes of motors, so increasing capacities later can be as easy as changing the motor and drive package.

Our pneumatic systems are economical and practical, with all the flexibility of a modular system that allows installation, expansion and rearrangement via Kongskilde's unique OK160 piping system that requires no tools — so changing the layout to fit current need is simple. Whether crops need to be conveyed horizontally, vertically or around corners, the quality will be protected by the Electronic Air Regulator. The Kongskilde solution is to use a high volume of air at low pressure to safely convey the product. The grain is truly moved on a cushion of air. This system provides an ideal way to fill bins, silos or flat storage. All the components are

easily transportable, making it easy to move them from one site to another, keeping investment costs low.

The TRL pneumatic conveying systems are suitable for wheat, barley, oats, rye, corn, canola, soybeans, and many other grains and granular products.

The Kongskilde single- and multi-stage "turbo impeller" fan is precision balanced and rotates freely to ensure a low noise level and continuous capacity regardless of age. The TRL 500, a three-stage blower, can deliver a pressure of no more than 5.63 PSI - 155 WG water gauge.

To introduce grain into the grain handling system, choose one of multiple sizes of air locks or Injector/Venturis. CAD rotary valves are used in pressure conveying for delivery into a horizontal pipeline, while CAE rotary valves are used in suction conveying systems for gravity discharge from cyclones. For lower capacities, the TF Venturi is used as an alternative to CAD rotary airlocks.

Direct Drive TRL



TRL 100 blower with TF 55 injector.



The motor directly drives the blower rotor.



TRL 50 blower for conveying fines.

The TRL blower creates an airflow in the pipes that conveys the grain. The amount of grain that can be blown through the pipes depends on the blower's power. Kongskilde provides blowers with different output to meet different needs. The small blower models are directly driven, i.e., the blower's rotor is fitted directly to the motor shaft.

Benefits

- Blower housings shaped in press toolings
- Dynamically balanced rotors provide smooth running
- Control of the air provides efficient conveying and minimizes pipe wear
- Minimal maintenance

Technical specifications	Motor HP (kW)	Power supply	Air volume Max CFM	Air pressure Max PSI (mm WG)	Weight lbs. (kg)	Motor RPM
TRL 30	3 (1.5)	115/230V or 230/460V or 575V	1,118*	0.36 (10)	80 (36)	3,600
TRL 50	5 (4.0)		1,530*	0.51 (14)	170 (77)	3,600
TRL 100	10 (5.5)		1,883	1.37 (38)	203 (92)	3,600

* Injector required (minimum back pressure from the injector necessary in order not to overload the motor).

Belt Driven TRL



Electronic air regulator.

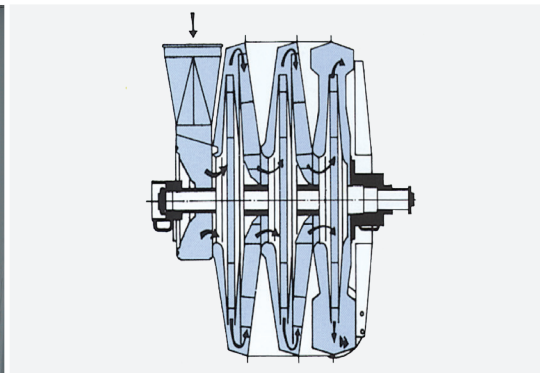

Construction of high pressure blower with 3 rotors.



V-belt drive for TRL 300 blower.

Higher capacities require higher pressure output from the blower. The most effective way to achieve this is by increasing the RPM. For this reason, the large blowers use a belt drive between the motor shaft and the blower shaft. In order to achieve more pressure for larger capacities, the large blowers have multiple rotors.

Benefits

- Effective modular system to build blowers with different outputs
- Proven design
- Air control ensures constant airflow for grain transport
- Can be used for both pressure and suction systems

Technical specifications	Motor HP (kW)	Air volume Max CFM (m ³ /h)	Air pressure Max kPa (mm WG)	Weight lbs. (kg)	Blower RPM	Motor RPM
TRL 210	10 (7.5)	1,060 (1,800)	9.3 (950)	284 (129)	3,650	3,600
TRL 215	15 (11)	1,060 (1,800)	12.8 (1,300)	311 (171)	4,200	3,600
TRL 220	20 (15)	1,060 (1,800)	17.0 (1,700)	454 (206)	4,700	3,600
TRL 300	30 (22)	1,060 (1,800)	22.6 (2,300)	764 (347)	4,100	3,600
TRL 500	50 (37)	1,060 (1,800)	34.4 (3,500)	1,030 (468)	4,300	3,600
TRL 750	75 (55)	1,060 (1,800)	62.8 (6,400)	2,123 (965)	4,310	3,600
TRL 1000	100 (75)	1,060 (1,800)	77.5 (7,900)	2,343 (1,065)	4,780	3,600

Twin Turbo



TRL Twin Turbo System

The Kongskilde TRL system allows for future expansion by pairing two blowers together. The two blowers can be connected together – twin turbo – when an increase in capacity is needed. The blowers are connected via permanent pipe requiring both blowers to run.

The other option is to connect the blowers using 2-way switches. This allows the operator to use one blower when conveying to a bin that is close by.

When moving grain a longer distance, just activate the second blower and move the handle on the switches. The Electronic Air Regulator adapts to the twin blowers, thus ensuring gentle conveyance of the commodity.

Electronic Air Regulator

The Electronic Air Regulator (EAR) is an intriguing component of the TRL conveying system. It allows the operator to adjust the air velocity according to specific criteria (conveying distance, crop, moisture, etc.) of the system. This provides the conveyance at maximum capacity while moving the grain gently to limit damage.

The EAR assures gentle conveyance of the grain in the pipe line. It is therefore ideally suited to act as a safeguard when conveying commodities such as corn, soybeans, peas and similar crops.

Minimum damage is achieved by conveying the product through the pipe system at a low air velocity. The orifice/sensing pipe provides the control box with the air pressure and flow data from the blower outlet.

The control box houses the main controller and power supply for the system. It contains the flow rate settings, startup time delay and operating parameters. The menu buttons are used for the system setup and flow rate while

the light bar display indicates the conveying range in which the TRL is operating. In addition, the control box formulates the data received from the orifice/sensing pipe. Using the flow rate menu allows the baffle in the shutter to be adjusted until the indicator needle is in the conveying range. The baffle position controls the amount of air going into the blower.



Rotary Airlocks and Injectors

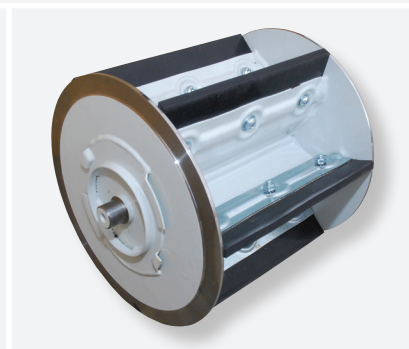

TF Injector/Venturi with inlet hopper.

CAD 40G rotary airlock with inlet hopper and slide gate.

CAE 20 rotary airlock mounted below the cyclone for bottom discharge.

Rotary airlock rotor with rubber paddles.

A rotary valve or injector delivers grain into the pipeline as part of a Kongskilde pneumatic conveying system. Injectors are ideal for low pressure conveying, while a rotary airlock is more appropriate for heavier material. The airlock is driven by a small HP motor.

CAD rotary valve units are used for pressure conveying, while CAE models are used for suction conveying.

Blower	TRL 30	TRL 50	TRL 100
Injector	TF 20	TF 40	TF 55

Benefits

- CAD rotary airlock is equipped with polyurethane paddles and a gear motor to run the unit
- Rubber paddles provide an excellent seal against air loss and they can bend to minimize clogging of material
- Standard inlet hoppers and shutters regulate the inlet volume

Technical specifications	Capacity t/hour	Motor HP (kW)	Cell wheel/motor RPM	Weight lbs. (kg)	Connection top/bottom	Max pressure kPa (mm WG)	Blower Model
CAD 20	16	0.75 (0.55)	65/1800	82 (37)	OK200/OK160	19.6 (2,000)	TRL 100-220
CAD 30	26.5	2.0 (1.5)	65/1800	135 (61)	OK200/OK160	39.2 (4,000)	TRL 300
CAD 40	53	2.0 (1.5)	65/1800	214 (97)	OK250/OK160	49.1 (5,000)	TRL 500
CAE 20	16	0.75 (0.55)	65/1800	71 (32)	OK200/OK200*	19.6 (2,000)	TRL 100-220
CAE 40	53	2.0 (1.5)	65/1800	196 (89)	OK200/OK200*	49.1 (5,000)	TRL 500
CAD 50	100	2.0 (1.5)	65/1800	88 (40)	OK160	80.0 (8,000)	TRL 750/1000

Capacities for TRL Systems

Conveying Capacity For Clean Dry Corn - Bu/Hour	Total Transport Length (Horizontal & Vertical) Feet Includes 40 Feet of Vertical Height															
	40	60	80	100	120	140	160	180	200	220	240	260	280	300	320	340
TRL 30 + TF 20	88	69	57	47	41											
TRL 50 + TF 40	140	126	114	104	96	88	79	73	67	62	56	51				
TRL 50 + CA 20	196	176	160	146	134	123	111	102	93	86	79	72				
TRL 100 + TF 55	343	315	285	250	229	208	190	178	164	151	137	122				
TRL 100 + CA 20	489	451	408	363	335	307	279	258	241	227	213	200	190	180	171	162
TRL 100 + Twin Turbo	880	812	734	653	603	552	502	465	434	408	384	360	342	324	308	292
TRL 210 + CA 20	543	501	453	403	372	341	310	287	268	252	237	222	211	200	190	180
TRL 210 + Twin Turbo	977	902	815	725	670	614	558	517	482	454	427	400	380	360	342	324
TRL 215 + CA 20	554	543	526	505	484	459	428	406	386	371	355	340	320	299	279	258
TRL 220 + CA 30	723	712	691	664*	628	587	541	511	486	466	445	425	404	383	363	344
TRL 220 + Twin Turbo	1,301	1,282	1,244	1,195	1,130	1,057	974	920	875	839	801	765	727	689	653	619
TRL 300 + CA 30	910	881	856	823	772	716	654	617	587	561	536	510	489	468	448	430
TRL 500 + CA 40	1,411	1,391	1,340	1,273	1,150	1,054	992	963	943	922	901	881	860	840	819	802
TRL 700 + CA 50	1,834	1,808	1,742	1,655	1,495	1,370	1,290	1,252	1,226	1,199	1,171	1,145	1,118	1,092	1,065	1,043

A Note on Conveying Capacities

Conveying capacities for pneumatic conveying systems depend on variables such as commodity, moisture content, temperature, humidity and pipe layout. Above capacities calculated with two bends in the line. For each additional bend, deduct 2%. For soybeans and wheat, deduct 20% off above capacities.

*Example: TRL 220 + CA 30 total pipe length 100 feet - 60' horizontal and 40' vertical = 664 Bu/hour.

Capacities

Various factors affecting the conveying capacity:

- Multiple bends reduce capacity
- Extra vertical pipe reduces capacity
- Moisture contents, above figures based on 14%
- Purity of the grain
- Air temperature, barometric and altitude pressure

Blower Curves

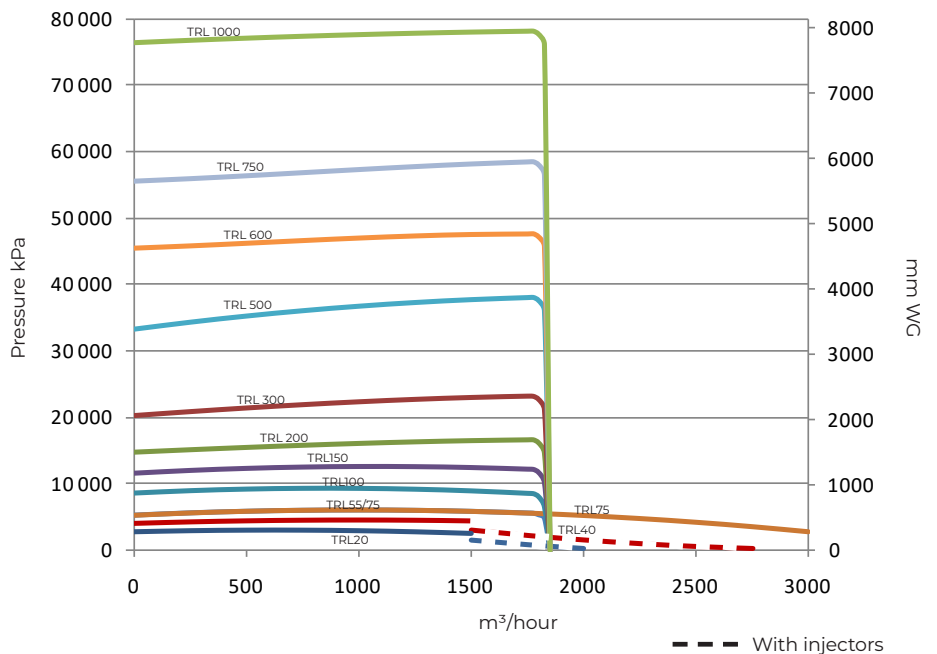

Electric-Powered SUC-E



Model SUC-E is trolley mounted for easy maneuverability.



SUC 500 E with mechanical air regulation.



Belt transmission protects drive of both blower and cell wheel.



SUC 500 E blower in the Kongskilde Grain Academy

Grain Vacs/Suction Blowers

Whether you need a temporary or permanent conveying system, Kongskilde has the vacuum and suction systems that will help you move grain where it needs to be. The wide range of electrical and tractor-powered grain vacs with capacities of up to 5,000 bushels of grain (120 tons) per hour means there's a blower for every job. The OK Pipe System makes it quick and easy to establish temporary or permanent pipelines.

How They Work

Suction blowers, also referred to as grain vacs, operate by the vacuum created by the turbine-style blower. The grain is drawn into the suction cyclone and is separated from the air inside the suction cyclone while the air is returned to the blower. The grain drops into the rotary valve, where it is fed into the air stream coming from the blower. The grain is directed through

the pipeline to the discharge cyclone. A discharge cyclone decelerates the grain and allows it to drop out of the bottom of the cyclone. Excess air is blown through the top of the discharge cyclone.

SUC-E 200, 215, 220, 300 and 500

The SUC-E models are often used at locations where tractor power units are not an option. They can be used both indoors and outdoors for all types of conveying jobs, including seed operations.

The SUC-E is equipped with a three-wheeled trolley, which makes the unit easy to move from place to place on hard surfaces. The five different sizes are designed to fit various capacity needs and power availability. Models from 10 HP to 50 HP are available with capacities of up to 1,800 bushels per hour.

Technical specifications	SUC 210 E	SUC 215 E	SUC 220 E	SUC 300 E	SUC 500 E
Blower Motor Power, HP (kW)	10 (7.5)	15 (11)	20 (15)	30 (22)	50 (37)
Rotary Airlock Motor Power, HP (kW)	0.75 (0.55)	0.75 (0.55)	0.75 (0.55)	1.5 (1.1)	2.0 (1.5)
Electrical connection, V/hz	115/230V – 230/460V – 575V				
Number of Rotors	1	1	1	2	3
Min. amp. fusing (recommended)	25	35	50	63	100
Weight incl. motors, lbs. (kg)	462 (210)	535 (243)	627 (285)	1,050 (477)	1,470 (668)
Max. air output, CFM (m ³ /h)	1,060 (1,800)	1,060 (1,800)	1,060 (1,800)	1,060 (1,800)	1,060 (2,000)
Type of conveying pipe	OK/OKR	OK/OKR	OK/OKR	OK/OKR	OK/OKR
Diameter of the conveying pipe, in (mm)	6 (160)	6 (160)	6 (160)	6 (160)	6 (160)

PTO-Powered SUC-T



Mounting frame for attachment to three-point hitch.



SUC 500 T compact design makes it easy to maneuver.



Three-state blower on SUC 500 T provides high capacity.



Mechanical air regulator is standard on all PTO-powered vacs.

SUC-T 300, 500 and 700

The SUC-T models are three-point hitch PTO-driven grain vacs. The blowers can be used to convey commodities to where high-capacity conveying is required and when no electrical

power source is available. The capacity of the SUC-T 500 is up to 1,800 bu/h (33 t/h).

Technical specifications	SUC 300 T	SUC 500 T	SUC 700 T
Recommended min. power of tractor PTO, HP (kW)	45 (34)	65 (48)	85 (62)
PTO shaft speed, RPM	540	540	1,000
PTO shaft dimension / tractor side	1 3/8" / 6 splines	1 3/8" / 6 splines	1 3/8" / 21 splines
Weight, lbs. (kg)	770 (350)	1,309 (595)	2,200 (1,000)
Blower max. air output, CFM (m ³ /h)	1,060 (1,800)	1,060 (1,800)	1,060 (1,800)
Type of conveying pipe	OK/OKR	OK/OKR	OK/OKR
Diameter of the conveying pipe, in (mm)	6 (160)	6 (160)	6 (160)

PTO-Powered SUC-TR



The vac's loading equipment ready for road transport.



The TR model loading equipment is ideal for loading trucks and trailers.



Powerful blower with up to 4 steps provides great conveying output.

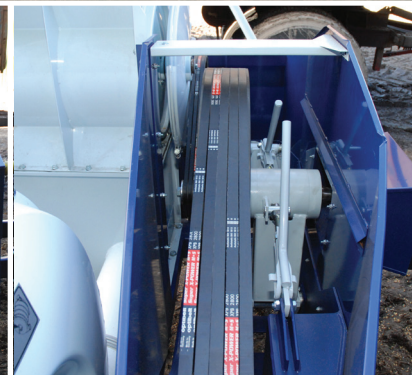

The belts can be tightened without using tools.

SUC-TR 500, 700 and 1000

The SUC-TR models are pull-type PTO-driven grain vacs that can be used to load trucks or grain wagons directly from the on-floor storage, silos or grain bins. They can also be used to

convey commodities to storage where high-capacity conveying is required. The SUC-TR is available in three sizes with conveying capacities up to 3,000 bu/h (90 t/h).

Technical specifications	SUC 500 TR	SUC 700 TR	SUC 1000 TR
Recommended min. power of tractor PTO, HP (kW)	65 (48)	85 (62)	120 (90)
PTO shaft speed, RPM	540	1,000	1,000
PTO shaft dimension / tractor side	1 3/8" / 6 splines	1 3/8" / 21 splines	1 3/8" / 21 splines or 20 splines
Weight, lbs. (kg)	1,804 (820)	1,694 (770)	2,310 (1,050)
Blower max. air output, CFM (m ³ /h)	1,060 (1,800)	1,060 (1,800)	1,060 (1,800)
Type of conveying pipe	OK/OKR	OK/OKR	OK/OKR
Diameter of the conveying pipe, in (mm)	6 (160)	6 (160)	6 (160)

PTO-Powered SupraVac 2000



SupraVac 2000 hydraulically folded into transport position.



Connection of discharge pipeline when filling bins or silos.



Fan guard reduces wear, removing abrasive material before it enters the fan.

SupraVac 2000

The SupraVac 2000 has a capacity of up to 5,000 bu/h (150 t/h), making it the ideal grain vac for farmers and commercial users. The power takeoff-driven SupraVac 2000 requires 150 hp. It has a hydraulic-folding truck loading boom that allows for quick setup. It conveniently locks into place for transport and storage

Pipes can be connected quickly to the rear of the SupraVac 2000 to blow product into grain bins, flat storage or sealed tower silos. It uses OK200 (8") piping for maximum capacity or can use existing OK160 (6") pipelines on storage structures at reduced capacity.

Technical specifications	SupraVac 2000
Recommended min. power of tractor PTO, HP (kW)	170 (125)
PTO shaft speed, RPM	1,000
PTO shaft dimension, tractor side	1 3/8" / 21 splines or 20 splines
Weight, lbs. (kg)	3,520 (1,600)
Blower max. air output, CFM (m ³ /h)	1,950 (3,300)
Type conveying pipe (suction side)	OKR
Type conveying pipe (pressure side)	OK/OKR
Diameter of the conveying pipe, in (mm)	8 (200)

Suction Heads



Selecting a Suction Head

All grain vacs, whether PTO or electric-powered, can be equipped with various suction heads to suit specific needs. Kongskilde offers a variety of suction heads for both OK160 and OK200 intake suction lines.

Selecting the right suction head for the conveying job in question provides the highest capacity and makes the job easier.



Round Suction Head:

For sucking grain from bulk storage or for use in auger hoppers for maximum capacities. This head is available in both OK160 (6") for SUC Models 500-1000 and OK200 (8") for SupraVac 2000.



Clean-up Head:

Final clean-up made easy with the extended handle, roller wheels on the bottom and a swivel link between the head and suction hose.

Fan Guard System

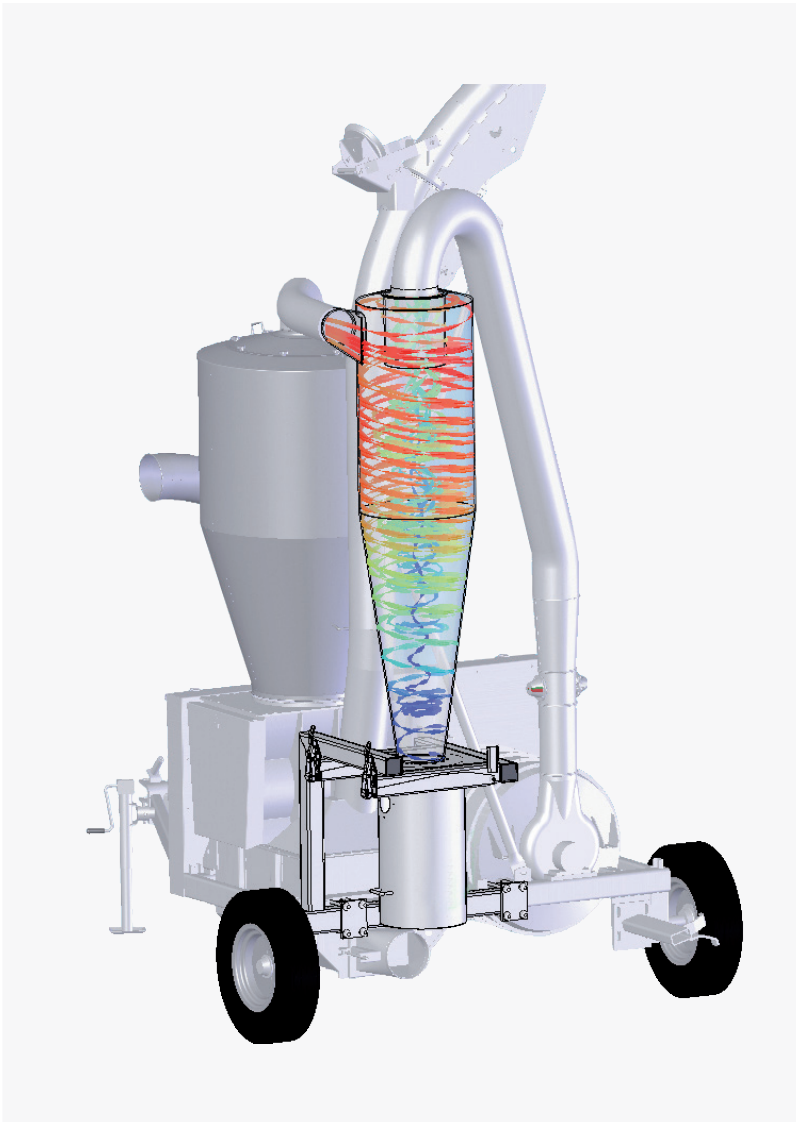

The Fan Guard System

While conveying crops from one place to another, there's another problem to consider: wear of blower units. Crops such as soybeans, peas and edible beans often contain a lot of abrasive foreign material that accelerates wear of the blower unit.

Kongskilde has developed the Fan Guard System to enhance the life of the blower of the SUC 1000 TR and SupraVac 2000

models. The Fan Guard System removes the majority of the dust and dirt particles from the air stream before they reach the blower housing.

The Fan Guard utilizes a high-efficiency dust cyclone in which the air must pass before entering the blower housing. The cyclone removes fine material, which is collected in an easily emptied canister directly under the cyclone.



Capacities for Grain Vacs

Conveying capacities for grain vacs depend on variables such as commodity, moisture content, temperature, humidity and pipe layout. Above capacities calculated with two bends in the line. For each additional bend, deduct 2%. For each additional 6' 5" (2.0m) added to the inlet suction line, deduct 2%. For soybeans and wheat, deduct 20% off above capacities.

*Example: SUC 1000 TR total pipe length 100 feet – 60' horizontal and 40' vertical and 15' of suction line = 2,934 Bu/hour.

Conveying Capacity For Clean Dry Corn - Bu/Hour	Total Transport Length (Horizontal & Vertical) Feet Includes 20 Feet of Vertical Height								
	40	60	80	100	120	140	160	180	200
SUC 210 E	280	258	235	210	200	185	150		
SUC 215 E	469	434	399	364	341	322	311	290	268
SUC 220 E	563	521	479	437	409	386	373	348	322
SUC 300 E/T/TR	853	759	698	651	604	568	544	521	497
SUC 500 E/T/TR	1,324	1,253	1,166	1,074	1,003	943	896	849	804
SUC 700 T/TR	1,748	1,677	1,556	1,418	1,324	1,251	1,204	1,138	1,072
SUC 1000 TR	3,059	2,934*	2,723	2,481	2,316	2,189	2,106	1,991	1,875
SupraVac 2000	4,589	4,401	4,085	3,722	3,474	3,284	3,159	2,987	2,813

Example

Inlet Suction Line

1 x Round suction head

1 x 6' 5" (2.0m) pipe and 1 x 8' (2.5m) steel flex hose

Discharge Line

Total transport length as noted includes 20' of vertical 4m vertical piping

2 x 90° bends

1 x Discharge cyclone

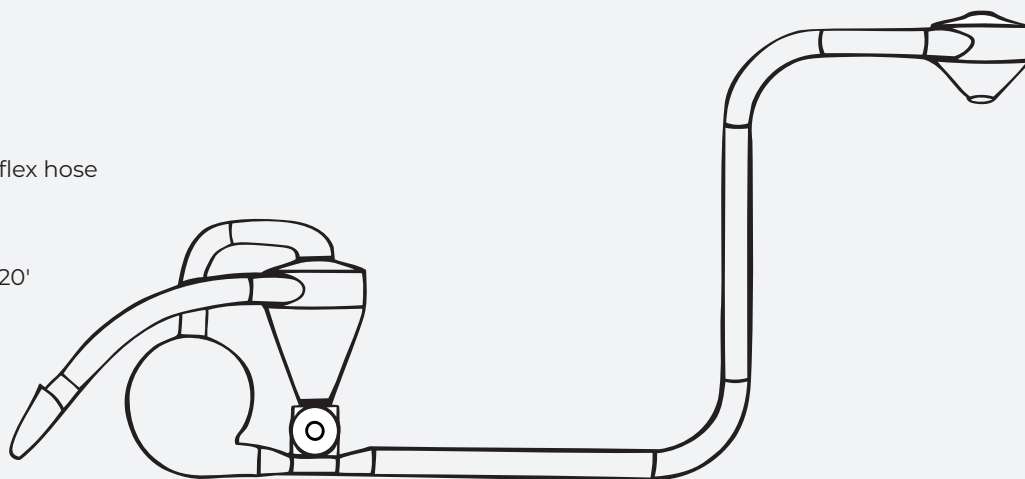

The capacities for the SupraVac 2000 apply when using Kongskilde's OK200 pipe system (diameter approximately 8"/200mm). For all the other grain vacs, the capacities apply when using Kongskilde's OK160 pipe system (diameter approximately 6"/160mm).

- Keep the suction side of the system as short as possible.
- Limit the use of suction hoses.
- Moisture content of the crop will influence capacity ratings.
- Fines in grain, like soil and dust, also influence capacity.

Connecting It All Together: The OK/OKR/OKD pipe system



Bolt clamps and quick-release coupling for assembly of pipe components

Assembly of pipes with quick-release coupling

Wide range of pipe components for easy construction of pipe systems

Every operation will have different requirements for capacity and layout. That demands a high degree of flexibility in choosing the piping systems that will allow all your equipment to work together. The Kongskilde OK Pipe System is ideal for pneumatic conveying applications. The simple and flexible pipe systems may be adjusted to suit any specific purpose, resulting in shorter conveying distances and therefore the most efficient and economical solutions.

Robust Construction

Galvanized sheet steel makes the OK pipe system sturdy. The rolled pipe ends serve as reinforcements, maintaining the circular shape and ensuring tight joints. Three choices of wall thickness are available, depending on the wear to which the pipe system will be exposed. Pipes are available in OK standard, OKR reinforced and OKD extra reinforced (for use after bends).

Full Utilization of the Air Stream

The advanced production machinery ensures a continuous, smooth inner surface of the pipeline, providing gentle and efficient conveying with and maximum utilization of the air stream.

Modular Pipe System

Designed in modular form, the OK pipe system comprises pipes, bends, branches, diverters, cyclones, outlets and other needed components, which are assembled quickly and easily using the unique OK quick-release clamp. The wide choice of OK pipes and accessories ensures flexibility and ease of installation in existing buildings. The modular design of the pipe system makes maintenance and alterations easier, and the relatively low weight of the OK pipes makes assembly easier.

Temporary and Permanent Installations

Two types of OK couplings are available for temporary and permanent systems. If the pipe system is to be dismantled or altered frequently, the OK quick-release clamp will make assembly and removal easy without the use of tools. For permanent systems, the OK bolt clamp is recommended.

Saved Floor Space

OK pipe supports permit wall and ceiling mounting, thus keeping clear valuable floor space in production areas or storage plants.

Note: OK160 and OK200 are standard piping systems while OKR160 and OKR200 are reinforced with heavier material thickness.



Trusted Pneumatic Systems Designed for the Grain Industry

Since 1949 Kongskilde Industries has been perfecting the science of pneumatic material handling systems and providing trusted solutions for the handling, cleaning, and weighing of grain and seed.

We Make Pneumatics Easy

Kongskilde has unparalleled experience delivering precisely engineered, expertly manufactured, customer-specific pneumatic conveyance and material handling products. Our wide range of products and know-how within grain handling processes provide a multitude of solutions for both conventional and organic farmers and others involved with grain handling.

Our legacy of innovation and passion for pneumatics spans more than 70 years and continues to accelerate with new technologies and bold ideas. With company headquarters in Denmark and sales offices in 9 countries around the world, we have the capacity and experience to truly think global and act local.



We continue to serve the needs of our customers across Central and North America from our location in Normal, Illinois in the heart of the grain belt. **Contact us to learn more or schedule a product demo.**



Kongskilde Industries USA, Inc.
1802 Industrial Park Drive, Unit A
Normal, IL 61761
Tel.: (309) 452-3300
kna@kongskilde-industries.com



