



Maximize the Value of Your Crop

**Efficient Solutions for Pre-Cleaning,
Sorting, and Grading of Grain**

Why Cleaning Is So Important

The Effects of Impurities

After threshing, grains are contaminated by impurities: Dirt, small pebbles, plant and insect waste, seed cases, weed seeds, etc.

These impurities hinder drying and safe storage operations and make them longer and more costly. Indeed, it would be not only costly but also superfluous to waste time, effort, and money on drying the impurities along with the grain.

These impurities lower the quality of the product and are also a focal point for potential infestation during storage. Cleaning may be accompanied by a sorting of the products according to quality, which is indispensable before storage, marketing, or further processing of the products.



How Can Cleaning Impact Your Business?

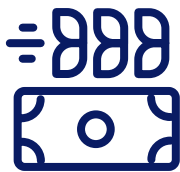

Cash Crop Farming

Seed cleaning alleviates problems caused by fungus or other unwanted remains sitting on the kernel surface.



Grain Processing

Secure the maximum output of your grain depending on its further use, i.e. seed or feed, by cleaning the grain.



Livestock Farming

Secure the maximum commodity output from your livestock with a proven feed handling solution.



Organic Farming

Take your organic production to the next level with solutions for efficient handling of crops and livestock.



Don't see your industry listed?

Don't worry, we're up for the challenge. Contact us for a custom solution.

Dual Cleaner KDC **PLUS**

The KDC is a cleaner with a dual cleaning function that utilizes both screen and aspirator technology. The screens sort the grain by means of size, and the aspirator unit removes light impurities and dust by means of air for exceptional cleaning capability.

The KDC PLUS features hinged doors for complete access to screens for easy screen replacement and visual inspection from either side. The inner screen serves as scalping, removing all large particles, and the total outer screen area is available for smaller fines removal. To achieve the optimal cleaning result, the angle of the machine can be changed to regulate the time the material stays on the screen.

The positioning of the aspirator after the screens ensures that smaller impurities and dust released on the screens are separated from the grain. Dust and smaller particles, together with the cleaned material from the inner screen, can be blown/transported up to 15 metres away.



KDC 8000 **PLUS**



Bottom of inlet made of heavy stainless steel for higher wear resistance.



Easy access for collection of grain samples after cleaning.



Windows on the side panel and aspirator unit can easily be cleaned or replaced.

Features and Benefits

- Quick-release system for easy and fast replacement of screens.
- Effective size separation of grain kernels through two layers of screens.
- Large selection of screens for all common crops.
- Cleaning by aspiration after size screening for maximum removal of dust.
- Limited stress and wear of cleaner with rotative parts only to avoid vibrations.
- All components exposed to the ambient are made in galvanized steel suited for outdoor installations.
- Wear spots are made in stainless steel.
- Dampers on the torque arm for gear drive reduce stress load on screen drum.
- A vacuum inside the drum compartment limits the amount of dust.
- Easy adjustment of screen drum angle by use of crank handle (standard on KDC 8000 PLUS).
- Easy access for collection of grain samples after cleaning.
- Easy inspection during operation through multiple windows.

Dual Cleaner KDC PLUS



KDC 8000 PLUS



Aspiration Cleaning

The aspirator unit is placed at the end of the cleaning system and is used to separate light impurities and dust from the grain.



Easy-to-open side panels which saves time and increase efficiency when changing screens.

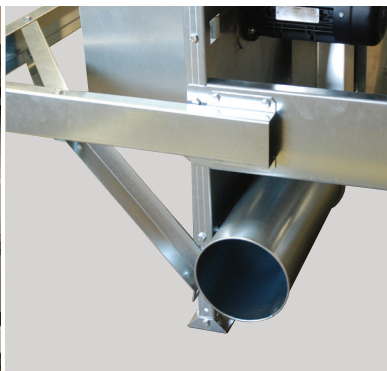

Screenings are conveyed through pipes up to 15 m away.



Cleaning brushes (optional) mounted on a spring loaded arm for efficient even load on the outer screens.



A quick-release system makes it easy and fast to change screens and make ready for the next crop.

Optionals

- Cleaning brushes clean the outer screens.
- Rain cover for motors.
- OK 200 pipe system and cyclone, connected to the outlet of the aspirator blower for conveying of impurities.
- Wheel set for short distance transport of KDC 4000/8000 PLUS between different locations.

Screens

Kongsilde Industries has in-house production of screens and offers a large assortment of efficient and robust screens for size separation of grain kernels. See separate data sheet "Screen Selection for KDC" for more details.



The most commonly used screens are now available in stock and can be shipped within 24 hours on regular workdays.

Technical Specifications	KDC 4000 PLUS	KDC 8000 PLUS
Max. capacity pre-cleaning, t/h*	40	80
App. capacity seed cleaning, t/h*	3 -17	6 - 34
App. capacity malting barley, t/h*	3 - 17	6 - 34
Screen drum drive motor size kW (HP)	1.5 (2.0)	2.2 (3.0)
Screen drum RPM	21.9	23
Blower for aspirator motor size kW (HP)	4.0 (5.5)	4 (5.5)
Blower for aspirator motor, RPM	3,000	3,000
Auger drive motor size, kW (HP)	0.75 (1.0)	1.1 (1.5)
Auger RPM	450	240
Control panel power supply (50 Hz)	3 x 400 V / Rated 13.4 A	3 x 400 V / Rated 15 A
Inlet for crop	OK 200	FK 250
Outlet for cleaned crop	OK 200	FK 250
Conveying pipes for impurities	OK 200	OK 200
Pipe outlet from auger	OK 160	OK 200
Screen area, Inner drum, m ²	4.1	7.5
Screen area, Outer drum, m ²	6.5	10
Weight, machine w/o screens and brushes, kg	890	1,750

*Grain 700 kg/m³. Capacity affected by grain type and condition, moisture, impurities, angling of KDC, selection of screens

How a KDC Works



Parameters Affecting Capacity

- Grain type and condition, moisture, impurities.
- Higher inclination of the adjustable legs makes the grain pass faster over the screens. This provides a higher capacity, but reduces the cleaner's effectiveness.
- Selection of screens. Inner screens with "small" holes provide a better cleaning at a lower capacity.
- How the cleaner is installed.

KDC 4000 **PLUS**

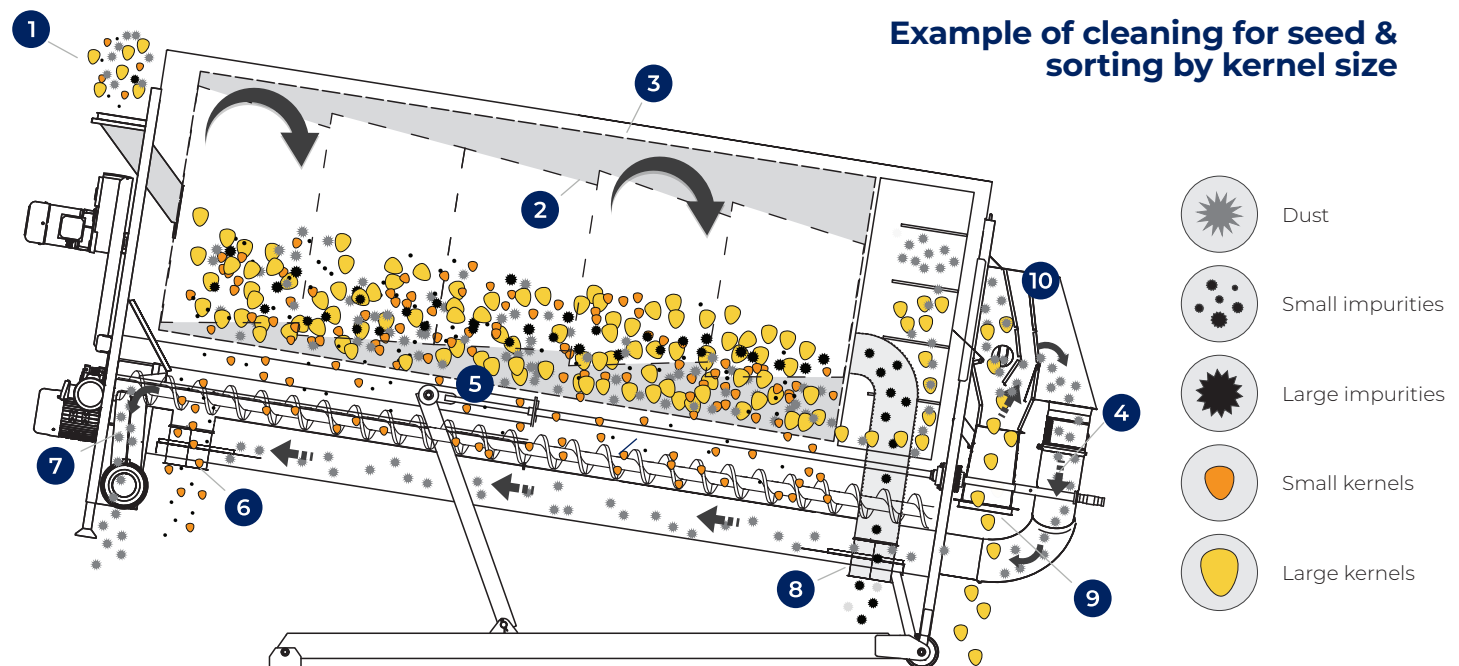

- | | |
|---|---|
| 1 Grain inlet | 6 Closable outer screen outlet for screenings / small kernels |
| 2 Inner screen, exchangeable | 7 Blower for aspirator |
| 3 Outer screen, exchangeable | 8 Closable outlet from inner screen |
| 4 Air bleed for air flow control in aspirator | 9 Clean grain outlet |
| 5 Auger for conveying of screenings | 10 Aspirator chamber for dust separation |

KF Aspirators

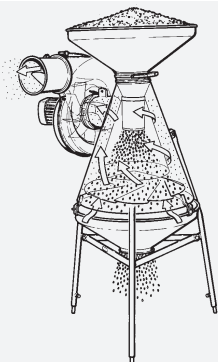

KF 12 mode of operation.



KF 12 model.

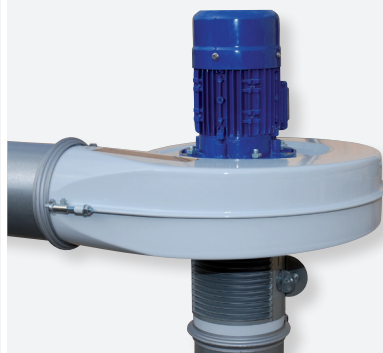

FRL 10 blower can be used to vacuum off dust, fines, and chaff at grain dryer discharge or at inlet to downpipe, auger, and conveyor inlets.



Cyclone for discharge of dust.

How an Aspirator Works

The grain passes through an upwards moving air stream in the aspirator. The air stream picks up dust and light impurities, and gravity allows the grain to fall down into the bottom outlet of the aspirator.

The dust and light impurities follow the air stream through the blower and further on into a pipeline to the desired discharge point.

Aspirators are suited for removal of dust and light impurities from grain. The construction of the pre-cleaner provides many options for integration in a grain plant.

We recommend that the grain cleaner is installed in such a way that it can clean the grain both before going into and coming out of storage.





KF 40 mode of operation.



KF 40 fitted with support legs.



Air regulator for adjustment of the suction power of the aspirator blower.

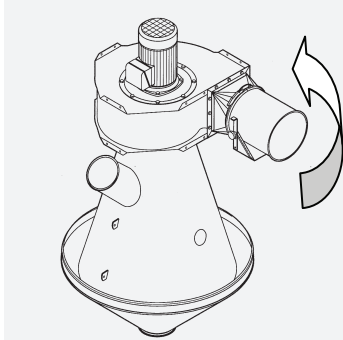

Blower outlet can be turned in any direction.

Benefits

- Modular system with great flexibility for built-in systems.
- Cost effective way to clean grain before going into storage or coming out.

Technical Specifications	KF 12	KF 20	KF 40	KF 60
Max. capacity (barley) t/h	12	20	40	60
Motor size blower motor kW (HP)	0.75 (1.0)	1.5 (2.0)	5.5 (7.5)	7.5 (10)
Motor RPM	3,000			
Motor type	Flange motor Norm motor B5			
Weight (incl. motor) kg	75	105	250	260
Conveying pipes for waste	OK 160	OK 200	FK 300	2 x FK 300
Max. recommended conveying length for waste (m)	25	15	15	15



Trusted Global Provider of Grain Handling Solutions **Since 1949**

Since its establishment in 1949, Kongskilde has consistently prioritized the development of products aimed at enabling the efficient, appropriate, safe, and gentle handling of grain commodities, with a notable emphasis on the role of air in this process.

Furthermore, Kongskilde has cultivated a substantial level of expertise in mechanical conveying, cleaning, storage, and drying, positioning the company as a pioneer with unique knowledge in pneumatic conveying systems within the agricultural industry.

In the present day, Kongskilde remains dedicated to providing highly efficient pneumatic conveying systems in diverse layouts, alongside mechanical conveying systems. Each type of system offers specific advantages tailored to distinct solutions, ensuring both flexibility and effectiveness. We extend our efficient and proven solutions from a wide range of products and systems, making them available locally or globally through our own subsidiaries or trusted partners. This philosophy continues to empower us to serve customers worldwide.



1210019716 EXP/CB/Cleaning/BRO/0125
Subject to be changed without notice.

kongskilde-industries.com/grain



Kongskilde Industries A/S

Tel.: +45 72 17 60 35

grain@kongskilde-industries.com

kongskilde-industries.com/grain